

Coin Counting Device Kinematic Diagram Development

Svitlana Maksymova, Vladyslav Yevsieiev

Department of Computer-Integrated Technologies, Automation and Robotics,
Kharkiv National University of Radio Electronics, Ukraine

Abstract:

Coin counting machines not only speed up the coin counting process, but also increase the accuracy and efficiency of cash handling, which is a key factor for businesses and organizations that handle cash. In this article, the authors consider the requirements that must be taken into account when developing coin counting machines. The main components of a coin counter are also discussed. Development of a kinetic scheme of a coin feeder.

Key words: Coin, Coin counting machine, Coin processing device, Kinematic diagram, Count automation.

Introduction

In order to speed up counting, accepting and storing funds in the form of coins, coin counting machines are used.

A coin counting machine is a device designed to automatically count and sort coins. It is commonly used in banks, supermarkets, arcades or other places where large quantities of coins need to be counted quickly and accurately. These machines can classify coins by their denomination, determine their quantity and total amount. They help automate the process of counting money and simplify routine work with coins.

They are designed for counting, grouping by denomination and packaging of coins with the rejection of deformed money and surrogates. Such devices are widely used in a wide variety of devices and machines [1]-[3]. Coin counters are necessary for bank vaults, cash registers that work with a large flow of small money, and large trading enterprises [4]-[9]. Using a coin counter saves time and labor costs when counting large numbers of coins. Today there are a large number of these devices with a different set of functions and capabilities, which allows them to be used both in small commercial institutions and in large banks.

When developing a coin counting machine, several key aspects are taken into account: counting accuracy, operating speed; ability to sort; reliability and durability;

ease of use; safety. One of the main requirements is high accuracy of counting coins of various denominations. The machine must be able to process large volumes of coins in a short time to ensure efficient use. Coin counting machines must be able to classify coins by denomination and, in some cases, identify counterfeit or damaged coins. These machines must be reliable and capable of operating without failure for long periods of time, especially when processing large volumes of coins. Good coin counting machines should be intuitive to use and have a user-friendly interface. This is an important aspect, especially in the banking and financial sector. The machines must be fraud-proof and have mechanisms to detect counterfeit coins. Also, such devices may have accompanying functions, such as packaging coins according to certain standards or creating counting reports for accounting.

When developing new coin counting machines, engineers strive to improve these parameters to ensure efficient and accurate operation in a wide range of applications. Therefore, various methods that have found application in other areas of research can be used here [10]-[19].

Later in this article we will consider the development of the kinematic diagram of such a device.

Related works

Many developers are currently creating their own coin counting machines for various purposes. Let's look at some of these works.

Munjal, R. and co-authors in [20] note that coins counting machines have to recognize coin sets from different countries and counterfeit coins. They also write that especially bimetallic coins, such as 2-Euro coins, are often subjected to counterfeit by mixing them with coins of other countries or by imitations. They propose a real-time embedded sensor system is proposed, based on inductance spectroscopy to characterize and identify bimetallic coins having similar geometric properties and looking similar at a first view.

Researchers in [21] consider acoustic resonance recognition of coins. The feature analysis methods combined with the employed classifiers achieved acceptable results, despite the relatively small dataset.

Authors in [22] write that there is an emerging need for a technology that can detect banknotes and coins to assist visually impaired people using the cameras embedded in smartphones.

Paper [23] outlines the steps involved in creating a mobile application for coin identification using machine learning. Using the neural network model, the

classification accuracy of successfully identified coins is recorded and disclosed. This study includes the limitations of the prototype mobile application and future improvements that could be added.

Scientists argue that the focus should be on understanding the semantic content of coins [24]. Hence, we describe a novel approach—to first extract semantic concepts from real-world multimodal input and associate them with their corresponding coin images, and then to train a convolutional neural network to learn the appearance of these concepts.

Article [25] notes that it is desirable to classify and correct counterfeit coins by utilizing the fewest possible measures.

The study [26] presents an automatic system for fake coins detection based on image content. In this study, a blob detector image-based method by fuzzy association rules mining is proposed to detect counterfeit coins. This research demonstrates the proposed framework is a reliable intelligent detection system and can be utilized for other applications based on image content.

Detecting a counterfeit coin using 2D image processing is nearly impossible in some cases, especially when the coin is damaged, corroded or worn out [27]. In paper [27], authors propose a 3D approach to detect and analyze the precipice borders from the coin surface and extract significant features to train an ensemble classification system.

Gakhar, S. in [28] proposes a counterfeit coin detection method that is robust and applicable to all types of coins, whether they have letters on them or just images or both of these characteristics.

Christian, J. B. in [29] note that advances in manufacturing, 3-d imaging, and globalization have led to a rise in fraudulent coinage and a world-wide interest in coin authentication. One promising method is in the use of finite mixture models to compare individual measurements of groups of coins to assist in authentication [29]. In [30] this author proposed detection method uses testing of many individual pieces, then using reverse-quality-engineering methods to identify possible sources.

Hmood, A. K., & Suen, C. Y. in [31] present a robust method for counterfeit coin detection based on coin stamp differences between genuine and counterfeit coins. A set of measures based on edge differences are proposed in this paper.

Coin Counting Basics

Like any modern banking equipment, coin processing devices must meet the following requirements:

- the ability to quickly and accurately recalculate and reject coins unsuitable for further use;
- ability to connect to automated banking systems of various configurations;
- high reliability, reduced noise level, accessibility and ease of operation and maintenance with a fairly quick payback.

There are currently three main coin counting technologies in use. The most common is based on the selection of coins by diameter and thickness. Another technology is based on the fact that when weighing coins of the same denomination (having approximately the same weight), knowing the average weight of one coin of a given denomination and the total weight of the coin mass, it is possible to determine the number of coins accepted and (or) collected amount as the product of the number of coins and their denomination. In case of significant discrepancies with the expected number of coins, we can assume:

- a coin of a different denomination (and weight, respectively) hits the counter;
- the presence of counterfeit coins in the processed mass, made from a different alloy and weighing more or less than a standard coin.

The advantage of this method is the high processing speed. Its disadvantages include the fact that when using significantly lighter tokens, but multiples of the weight of real coins, under some conditions it is possible to erroneously determine the number of coins and the amount collected, respectively. Checking coins for authenticity is practically impossible. To quickly control the amount of coins in the cash register, special coin trays with a measuring scale are used. The recesses in the trays are located denominationally and are made according to the diameter of the coins of the corresponding denomination. The graduation of the scale corresponds to the thickness of the coins and is performed in units of the number and amount of coins of a given denomination. Thus, by looking at the tray, you can immediately determine the number and amount of coins contained in it. As a rule, portable mini-cash registers are equipped with such coin trays. They are very convenient and allow you not only to store and issue change, but also to quickly determine how many change coins are in the cash register.

The most common method is to select coins of a given diameter and thickness, while simultaneously recalculating their number and rejecting all other coins. This idea is the basis of most coin or token counters and sorters currently in use.

Coin counting device kinematic diagram development

There are currently two main coin counting technologies in use. The most common one is based on measuring the diameter and thickness of coins. Another technology is based on the fact that when weighing coins of the same denomination (having approximately the same weight), knowing the average weight of one coin of a given denomination and the total weight of the coin mass, it is possible to determine the number of accepted coins and/or the collected amount as the product number of coins per their face value. In case of significant discrepancies with the expected number of coins, we can assume: a) a coin of a different denomination (and weight, respectively) entered the counter; b) the presence of counterfeit coins in the processed mass, made from a different alloy and weighing more or less than a standard coin.

The coin counter counts and sorts all types of coins. Two independent counter adjustment knobs allow the operator to set the diameter and thickness of the coin for sorting.

Main parts of the coin counter:

- load-bearing base;
- thickness adjustment mechanism;
- guiding mechanism;
- carriage with coin conveyor;
- counting block;
- disk in the counting bin;
- device for determining dignity;
- device for bent coins;
- sensor for the number of coins in the hopper;
- electromechanical drive;
- coin conveyor in the loading hopper.

Separation is based on the passage of coins through a slot (adjustable), and separation by diameter is based on holding the guide of the mechanism. The height separation mechanism is made in the form of a damper, which is part of the wall of the counting hopper, or in the form of a separating roller. Next comes the mechanism guide in the form of two bars, one of which is fixed and the other is movable, allowing you to change the size of the coins (Figure 1).

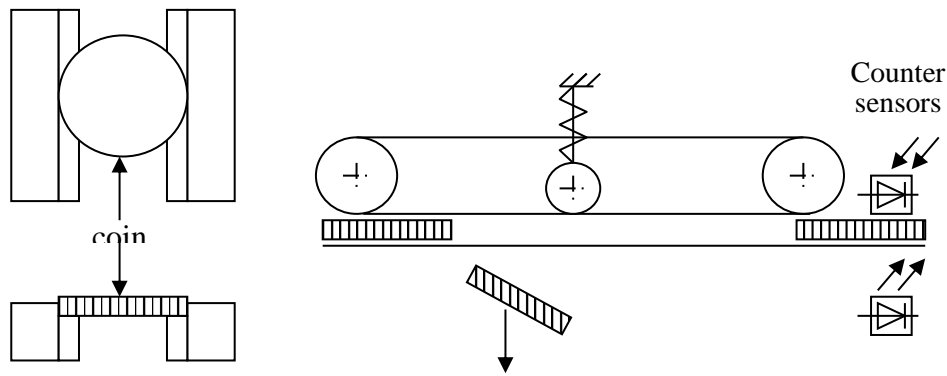

Figure 1: Coin counting machine transport mechanism.

The counting sensor can be optoelectronic or inductive.

Figure 2 shows the kinematic diagram of the coin feeder

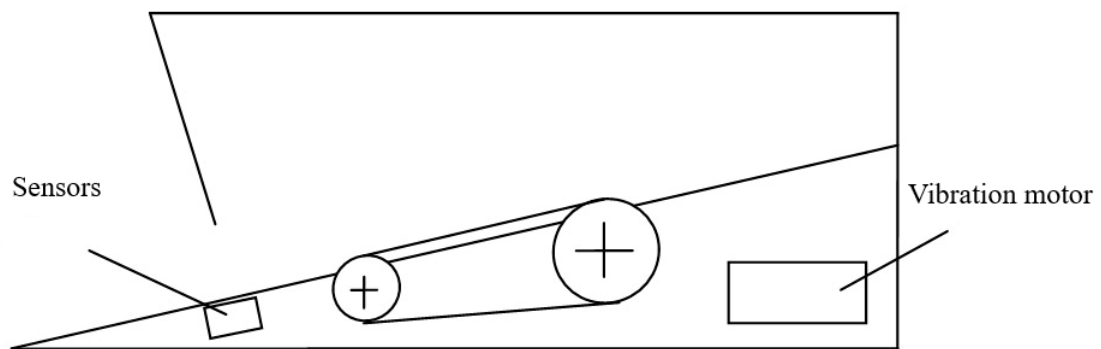

Figure 2: Kinematic diagram of the coin feeder

The coin feeder is equipped with a vibration motor to better feed coins and prevent coins from getting stuck. The device is equipped with a coin feeding belt and sensors for filling the coin feeding hopper.

Conclusion

Coin counting machines have several important uses:

- saving time - manually counting large volumes of coins can be very labor-intensive and time-consuming; coin counting machines significantly speed up the counting and sorting process;
- counting accuracy - ensuring high counting accuracy, minimizing the likelihood of errors that may occur during manual counting;
- convenience and efficiency - the use of coin counting machines increases the efficiency of banking and financial transactions, simplifies accounting and facilitates

the work of cashiers, trading enterprises and other organizations working with a large number of coins;

- sorting and filtering - some coin counting machines can not only count, but also sort coins by denomination, remove damaged or counterfeit coins, which helps ensure the purity and accuracy of financial transactions;

- professional use - banks, retail chains, arcades and other institutions where a large number of coins are used find coin counting machines as a reliable assistant to facilitate the work with money.

This article provides an analysis of the requirements for coin counting machines. A list of the main components of the device being developed has been compiled. It must contain load-bearing base; thickness adjustment mechanism; guiding mechanism carriage with coin conveyor; counting block; disk in the counting bin; device for determining dignity; device for bent coins; sensor for the number of coins in the hopper; electromechanical drive; coin conveyor in the loading hopper.

The following is a kinematic diagram of the proposed coin counting machine.

In the future, it is planned to carry out three-dimensional modeling of the device being developed: select a modeling environment, model the main parts of the coin feeder, create an assembly of a coin counter, and also simulate the load. And after that it will be possible to create a physical device.

References:

1. Meisu, Y. (2020). Design of vending machine based on PLC. In 2020 IEEE 9th Joint International Information Technology and Artificial Intelligence Conference (ITAIC), 9, IEEE, 1032-1035.
2. Zharikova, I., & et al. (2023). Automatic Machine of Plastic Bottles and Aluminum Cans Collection for Recycling. Journal of Universal Science Research, 1(11), 169-178.
3. Zisopoulos, A. (2021). MIDAS, Repository With'Nder the Pillow Gold'Using Antipodal Unique Identification of Golden Coins for Regional Development and Monetary Applications. Review of International Geographical Education, 12(01), 2022.
4. Азаренкова, Г., & Ляшенко, В. (2009). Відношення переваг у порівняльній оцінці діяльності банків. Банківська справа, 5, 65-72.
5. Kots, G. P., & Lyashenko, V. (2012). Banking sectors of the economies of European countries in the representation of statistical interrelation between

- indices that characterize their development. *European Applied Sciences*, 1, 461-465.
6. Куштим, В. В., & Ляшенко, В. В. (2007). Динаміка розвитку банківського сегмента міжнародного фінансового ринку. *Фінанси України*, (12), 96-105.
 7. Коц, Г. П., Кузьомін, О. Я., & Ляшенко, В. В. (2010). Сучасні методи аналізу функціонування банків: розв'язання проблемних аспектів. *Восточно-Европейский журнал передовых технологий*, 5(3 (47)), 48-52.
 8. Vasiurenko, O., & et al.. (2022). Financial Flows Management Based on the Analysis of Their Interaction. *International Journal of Academic Management Science Research (IJAMSR)*, 6(9), 200-206.
 9. Kuzemin, A., Lyashenko, V., Bulavina, E., & Torojev, A. (2005). Analysis of movement of financial flows of economical agents as the basis for designing the system of economical security (general conception). In *Third international conference «Information research, applications, and education* (pp. 27-30).
 10. Abu-Jassar, A. T., Attar, H., Yevsieiev, V., Amer, A., Demska, N., Luhach, A. K., & Lyashenko, V. (2022). Electronic User Authentication Key for Access to HMI/SCADA via Unsecured Internet Networks. *Computational Intelligence and Neuroscience*, 2022, 5866922.
 11. Слюніна, Т. Л., Бережний, С. Б., & Ляшенко, В. В. (2007). Розвиток вітчизняної мережі банківських установ: особливості та регіональні аспекти. *Вісник ХНУ ім. В. Н. Каразіна. Економічна серія*, 755. 84–88.
 12. Lyashenko, V. (2014). Efficiency of bank crediting of real sector of economy in the context of separate banking groups: an empirical example from Ukraine. *International Journal of Accounting and Economics Studies*, 2(2), 74-79.
 13. Baker, J. H., Laariedh, F., Ahmad, M. A., Lyashenko, V., Sotnik, S., & Mustafa, S. K. (2021). Some interesting features of semantic model in Robotic Science. *SSRG International Journal of Engineering Trends and Technology*, 69(7), 38-44.
 14. Abu-Jassar, A. T., Al-Sharo, Y. M., Lyashenko, V., & Sotnik, S. (2021). Some Features of Classifiers Implementation for Object Recognition in Specialized Computer systems. *TEM Journal: Technology, Education, Management, Informatics*, 10(4), 1645-1654.

15. Nevliudov, I., & et al.. (2020). Method of Algorithms for Cyber-Physical Production Systems Functioning Synthesis. *International Journal of Emerging Trends in Engineering Research*, 8(10), 7465-7473.
16. Nevliudov, I., Yevsieiev, V., Lyashenko, V., & Ahmad, M. A. (2021). GUI Elements and Windows Form Formalization Parameters and Events Method to Automate the Process of Additive Cyber-Design CPPS Development. *Advances in Dynamical Systems and Applications*, 16(2), 441-455.
17. Lyashenko, V., Tahseen, A. J. A., Yevsieiev, V., & Maksymova, S. (2023). Automated Monitoring and Visualization System in Production. *Int. Res. J. Multidiscip. Technovation*, 5(6), 09-18.
18. Lyashenko, V., Sotnik, S., & Manakov, V. (2021). Modern CAD/CAM/CAE Systems: Brief Overview. *International Journal of Engineering and Information Systems (IJEAIS)*, 5(11), 32-40.
19. Sotnik, S., Lyashenko, V., & Schakurova, T. (2021). Modern Integrated Software Development Environments. *International Journal of Academic and Applied Research (IJAAR)*, 5(10), 157-161.
20. Munjal, R., & et al. (2020). Multifrequency inductive sensor system for classification of bimetallic coins. *IEEE Transactions on Instrumentation and Measurement*, 70, 1-9.
21. Kraljevski, I., & et al. (2020). Acoustic Resonance Recognition of Coins. In *2020 IEEE International Instrumentation and Measurement Technology Conference (I2MTC)*, IEEE, 1-6.
22. Park, C., & et al. (2020). Deep feature-based three-stage detection of banknotes and coins for assisting visually impaired people. *IEEE Access*, 8, 184598-184613.
23. Nazly, D. Q. M., & et al. (2023). Malaysia coin identification app using deep learning model. *Bulletin of Electrical Engineering and Informatics*, 12(4), 2506-2512.
24. Cooper, J., & Arandjelović, O. (2020). Learning to describe: a new approach to computer vision based ancient coin analysis. *Sci*, 2(2), 27.
25. Chen, L. (2023). Continuum Mapping and S-base Space Solution to Coin Weighing Problem. *Preprints.org*; 2023.
26. Rad, M. S., & et al. (2020). A Blob Detector Images-Based Method for Counterfeit Coin Detection by Fuzzy Association Rules Mining. In *International Conference on Pattern Recognition and Artificial Intelligence*, Cham: Springer International Publishing, 669-684.

27. Khazaei, S., & et al. (2021). Detection of counterfeit coins based on 3D height-map image analysis. *Expert Systems with Applications*, 174, 114801.
28. Gakhar, S. (2020). Local Image Patterns for Counterfeit Coin Detection and Automatic Coin Grading, Concordia University, Spectrum Research Repository, 986780
29. Christian, J. B. (2022). Population identification strategies for counterfeit coin detection. *Journal of Forensic Sciences*, 67(5), 1989-1997.
30. Christian, J. B. (2023). Model verification for population detection of counterfeits. *Journal of Forensic Sciences*, 68(6), 2169-2183.
31. Hmood, A. K., & Suen, C. Y. (2020). Statistical edge-based feature selection for counterfeit coin detection. *Multimedia Tools and Applications*, 79(39-40), 28621-28642.