

,

()

()

()

()

:

II , _____ -20-1

(,)

123 - ,

()

-

(- -)

()

:

(; ,)

() _____ (,)

,

()

123 – ’

()

-

(- -)

()

:

“ ” 2021 .

(, ,)

1.

“ 05 ” 2021 . 1657

2.

13

2021 .

3.

1.

2.

RTI (Run Time Infrastructure)

3.

4.

1

2

3

RTI

5. _____ , , , ,
 () _____
 . -12 . . 4

6. _____ (_____ -
 , .1) _____

-	(, , , ,)		

1		09.11.21 – 11.11.21	
2		12.11.21 – 24.11.21	
3		25.11.21 – 29.11.21	
4		30.11.21 – 02.12.21	
5		02.12.21 – 05.12.21	
6		06.12.21 – 11.12.21	
7		12.12.21 – 13.12.21	
8		14.12.21 – 15.12.21	

_____ () _____
 | _____ () _____ (; ,) _____

: 59 ., 14 ., 1 ., 17

(middleware)

(HRT),

(RTI),

ABSTRACT

Master's thesis: 59 pages, 14 figures, 1 appendices, 17 sources.

SOFTWARE, DISTRIBUTED SIMULATION, REAL-TIME SIMULATION ENVIRONMENT, INFORMATION SYSTEM

Software for distributed simulation of information systems often uses middleware to provide services to support their performance in distributed computing environments. This middleware covers many levels, from low-level support for data transfer through resource request brokers to high-level simulation functionality such as time management. The paper considers methods and tools for designing and implementing such intermediate software for distributed real-time simulation (HRT), for example, applications with hardware in the loop. The implementation of the real-time infrastructure (RTI) middleware software is described, the distributed modelling method and the performance of such tools are compared with the non-real-time implementation.

	,	,	,	8	
				9	
1				13	
1.1				13	
1.2				15	
1.3	HLA			15	
1.4				16	
1.5		,	'	HLA	17
1.6			HLA	18	
1.7	ADSF			18	
2				20	
2.1				20	
2.2				22	
2.3				23	
2.4				25	
2.5				27	
2.6				30	
2.7				32	
3	RTI			37	
3.1				37	
3.2		,		39	

3.3	43
3.4	HLA.....	46
	49
	51
	53

-
-
- GUI – (Graphic User Interface)
- API – (Application Programming Interface)
- ClassAd – Classified Advertisement
- ID – identity
- FCFS – First-Come First-Served
- HAL – Hardware Abstraction Layer
- HLA – High Level Architecture ()
- HPF – Highest Priority First
- TORQUE – Terascale Open Source Resource and Queue Manager
- RTI – Run-time infrastructure
- SLURM – Simple Linux Utility for Resource Management
- VM – virtual machine
- VMM – Virtual Machine Monitor
- VPN – virtual private network

(HLA)

HLA,

(IFSpec) [1],

HLA

(RTI)

RTI-Kit,

RTI [2].

RTI

(WCT).

(RO)

HLA,

(TSO).

RO,

[3].

(HWITL),

,
 RO.
 HLA IFSpec RTI,
 . tick() ,
 , RTI
 tick(). , ,
 . -
 , ,
 RTI
 , ,
 HLA
 HWITL .
 HWITL,
 HLA .
 , - , RO .
 , , -
 , , -
 , .
 - .
 VV&A. ,
 .
 ,
 HLA RTI.
 HLA , , , ,
 -
 .

RTI,

RTI

1

2

3

()

(M&S),

Simulation Based

Acquisition (SBA) [1].

(ADD)

(Chelmae-II), M&S [2].

(DoD)

(HLA)

1516

(IEEE) 2000 [1]. M&S

HLA. ChangJo21, ChungHae

ChangGong ChunJaBong

HLA [5, 6, 7].

M&S RDSE

HLA

(TCP/IP)

/
(UDP),

HLA

HLA

[8, 9].

RDSE.

RDSE,

HLA,

1

1.1

,

(DIS)

DIS

.

,

,

(

).

DIS.

-

,

DARPA,

WarBreaker,

,

DIS.

,

(SBA),

,

,

(RDT&E).

HLA

,

HLA

,

(

)

,

[16].

HLA RTI

,

,

UDP / TCP.

M&S,

,

.

TCP UDP.

(VRTP)

[13],[15].

[14],

[10].

CORBA[11]

[12].

VRTP,

CORBA

[4]

[5].

QoS

RTI,

[17].

HLA

HLA-

RTI

HWITL,

HLA-

(.

<http://www.opal-rt.com>),

(RTOS).

HLA , (OMT)
 . (RTI) —
 , HLA
 ,
 HLA.
 HLA HLA
 [11].
 , HLA,
 .
 , (), RTI , (FOM)
 [1,5].

1.4

,
 [8]. ,
 , « » ,
 [14].
 ,
 . ,
 , : «
 ».
 , ,
 ,
 , . ,
 ,

1.5 , ' HLA

[6] HLA Federation Class (HFC) HLA
Automation Tool (HAT) HLA . Belanger

. [14, 15] OSim

HLA. OSim OSim BulleinBoard,
, OSim Executor,
, OSim Generator,
C++ Java, BulleitionBoard
Executor. . [16] FedProxy
Java
, FedProxy
,
. Elias Huiskamp [17]
(ASF),
(DIS) HLA
. ASF ,
. Pilloud Kanko [18]
SIMWORX, ' -
, DoD HLA M&S
DIS. SIMWORX Ada95
. [19] ,
(LP). . [5]
RTI Object Model (ROM),
RTI .
, ChangJo 21. ,
, HLA,
, .

1.6

HLA

Raytheon, (FMS)
 T&E Patriot. FMS – T&E,
 M&S T&E,
 . FMS

M&S T&E

[20].

, Raytheon Standard Missile
 (SM)-3, HLA [21].

Gepard Hardware-in-Loop (HIL)

M&S, HLA,

(DT)

(OT)

Gepard [22].

1.7

ADSF

HLA

RDSE.

TCP/IP

UDP.

HLA, TCP/IP

UDP

. RDSE

2

2.1

(WCT) , - ,

[6]. , ,

WCT.

WCT, .

òDISÓ.

Æt. , 2)

: 1)

3)

Æt, ,

RO

().

() dt, dt.

, dt

dt

2.1.

dt,

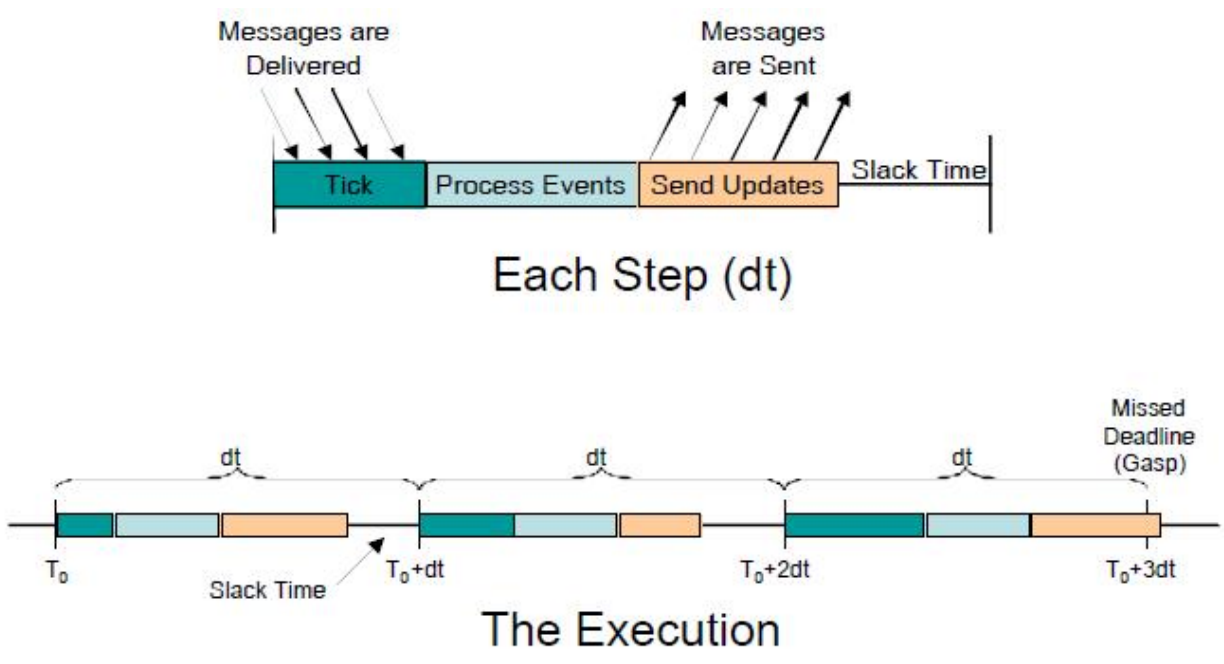

2.1 -

WCT

« ».

2.2

(LP)

LP —

LP.

RTI.

RTI

, RTI

2.3

RTI

RTI,

RTI,

tick()

RTI.

RO.

RTI

RTI

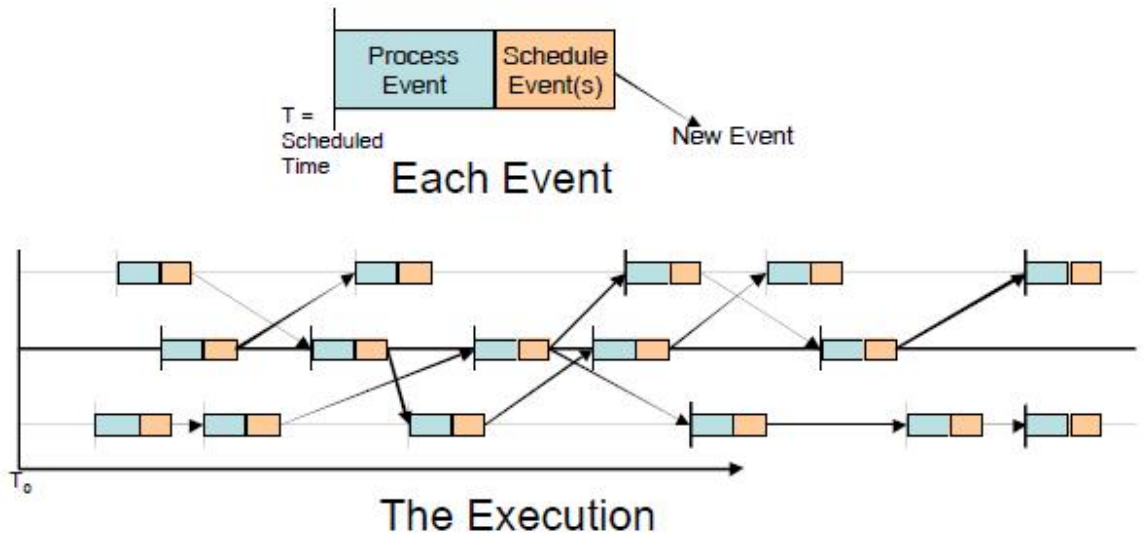

2.2 -

(QoS)
WCT,

QoS

QoS.

RTI

(AFAP).

AFAP

WCT,

RT,

() WCT.

(HRT)

HRT.

Georgia Tech RTI-Kit,

RTI.

2.4

RT

HLA

RT

RTI,

HRT, RTI

2.3.

HLA

TSO RO,

tick()

TSO

, RTI

WCT.

2.3

(

),

(1).

RTI

(2).

(3).

RTI

FEDERATE

RTI

RTI

RTI

(LRC).

DDM

[8].

2.4

RTI

WCT

- 1.
2. RTI
3. RTI
4. RTI

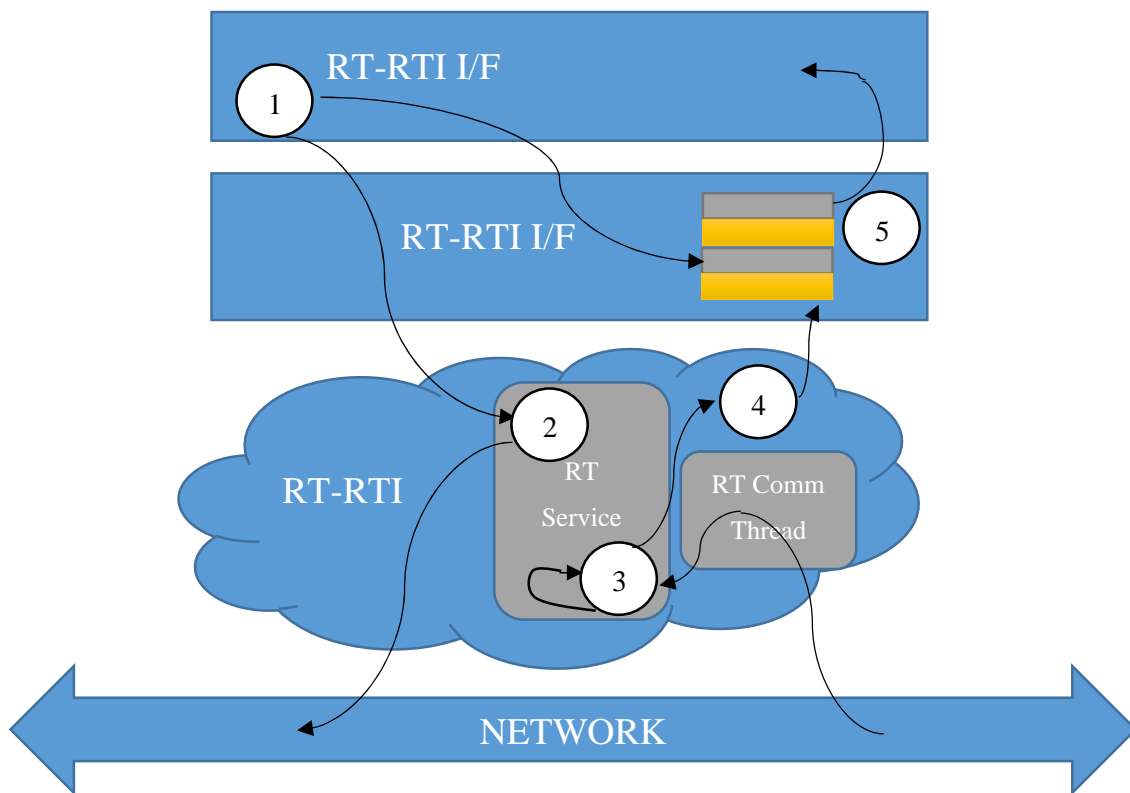

5.

.
 ,
 RTI .
 ,
 (RTI),
 RTI
 ,
 . RTI
 .

2.6

. RTI
 , HLA,
 RT. HRT RTI
 ,
 2.5. RTI, ,
 , RTI
 . RTI ,

2.5.

- , RT State Engine (1);
 - RTI , RT State Engine (2);
 - RTI RT(3);
 - RTI
- RT (4).

RTI,

. RTI QoS

, SF,

SF*WCT.

RTI.

RTI, WCT,

WCT.

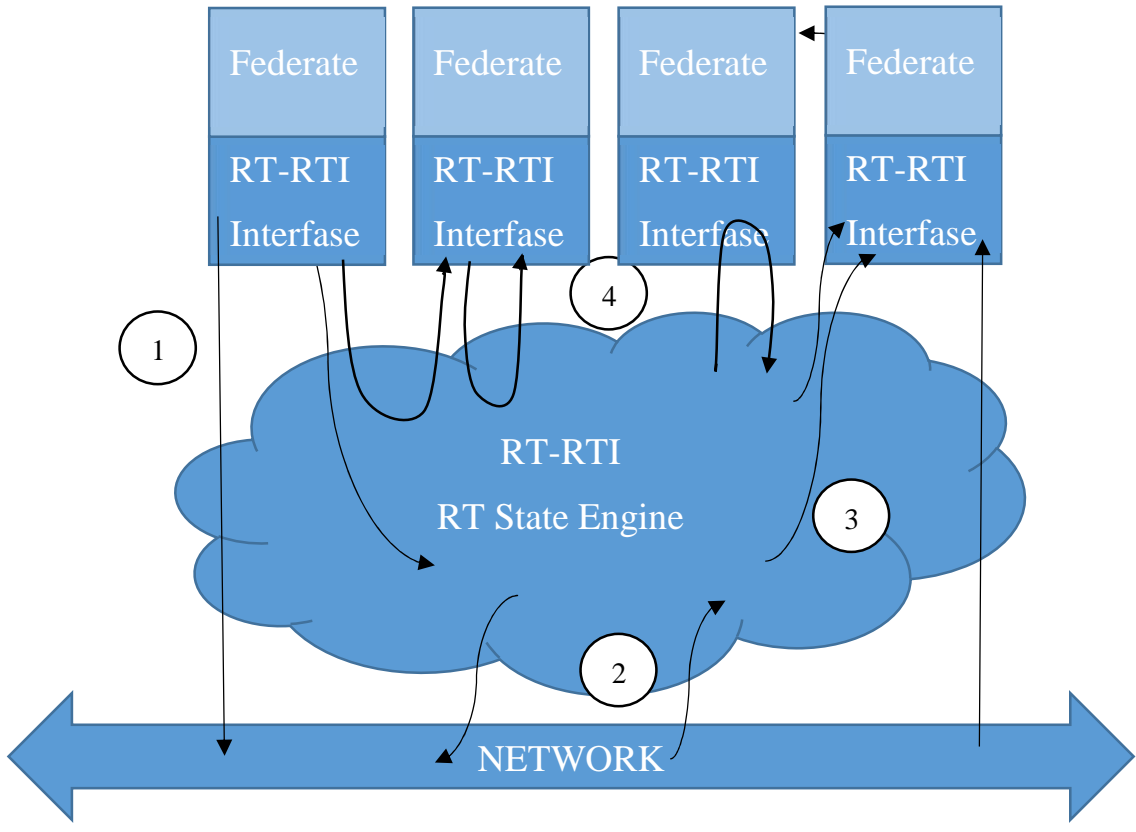

2.7.

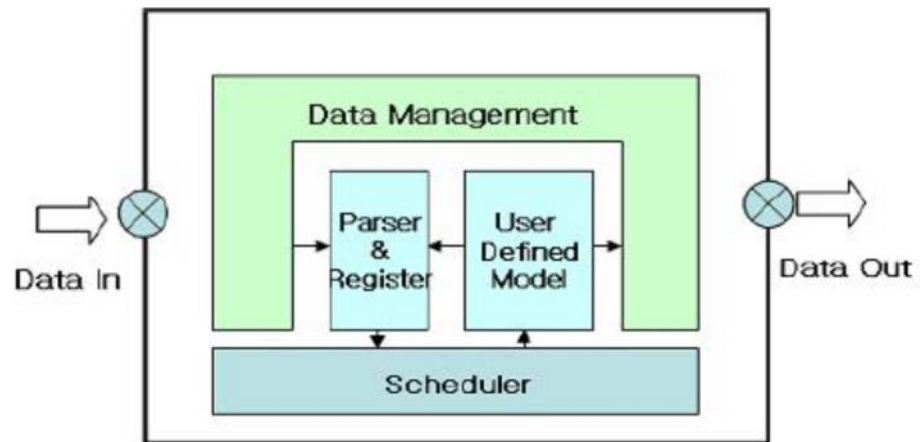

2.7 -

User Defined Model

2.8.

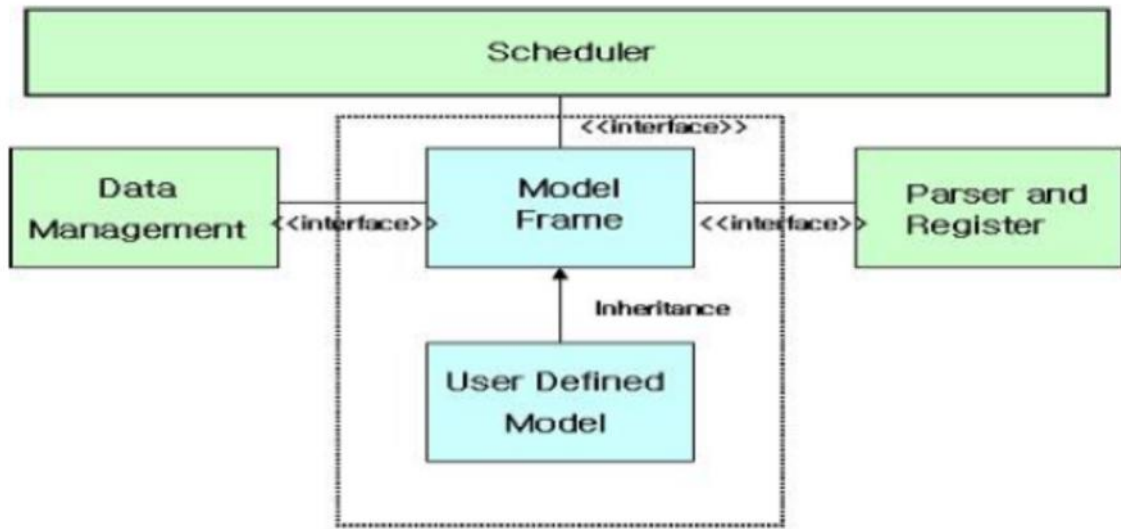

2.8 –

2.9

RTI

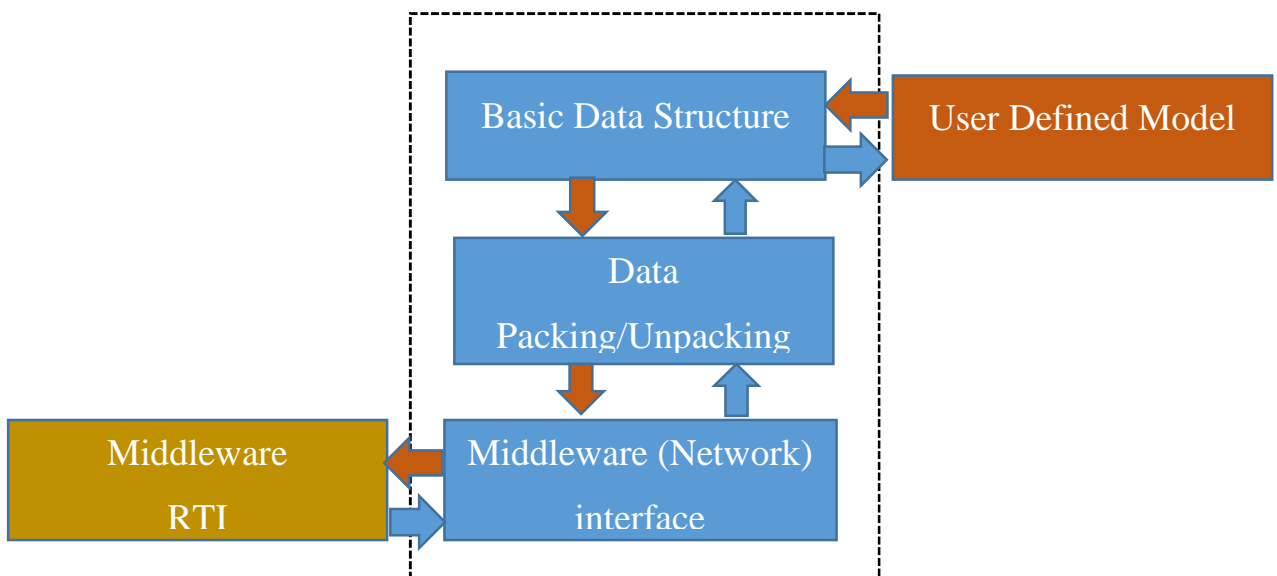

2.9 –

2.10

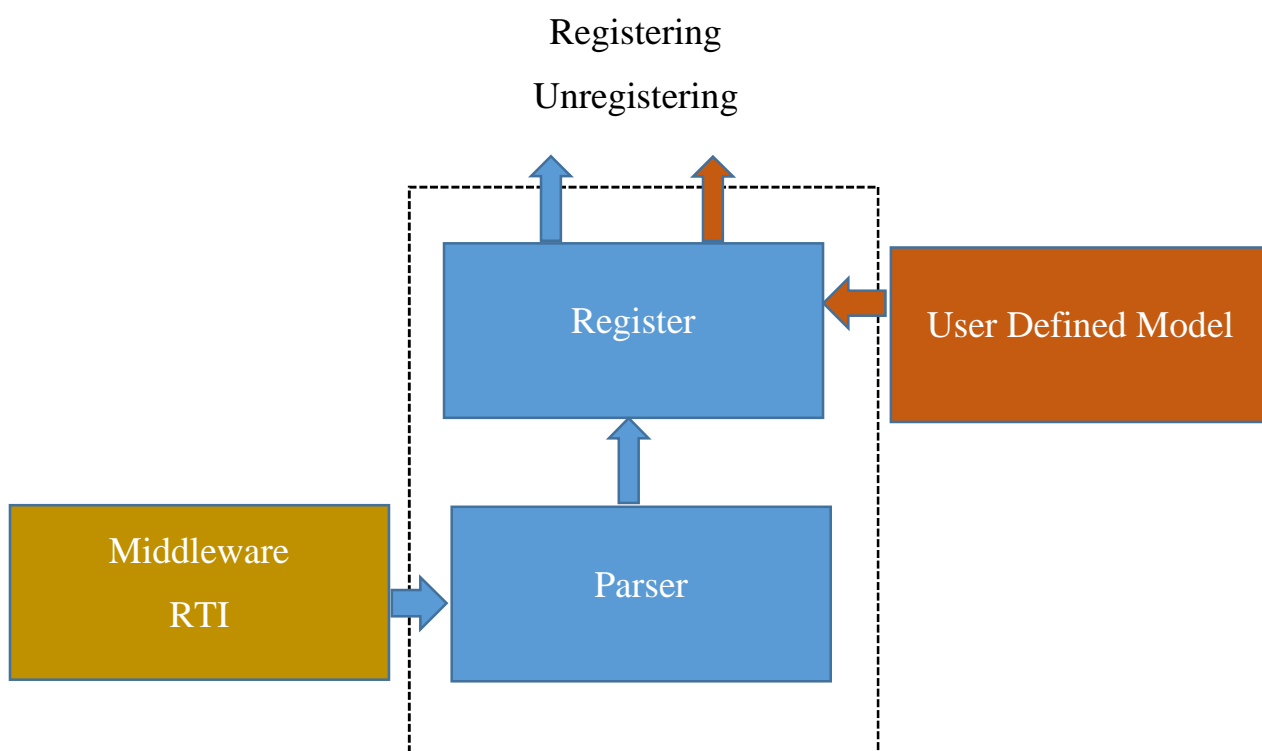

2.10 -

()

2.11

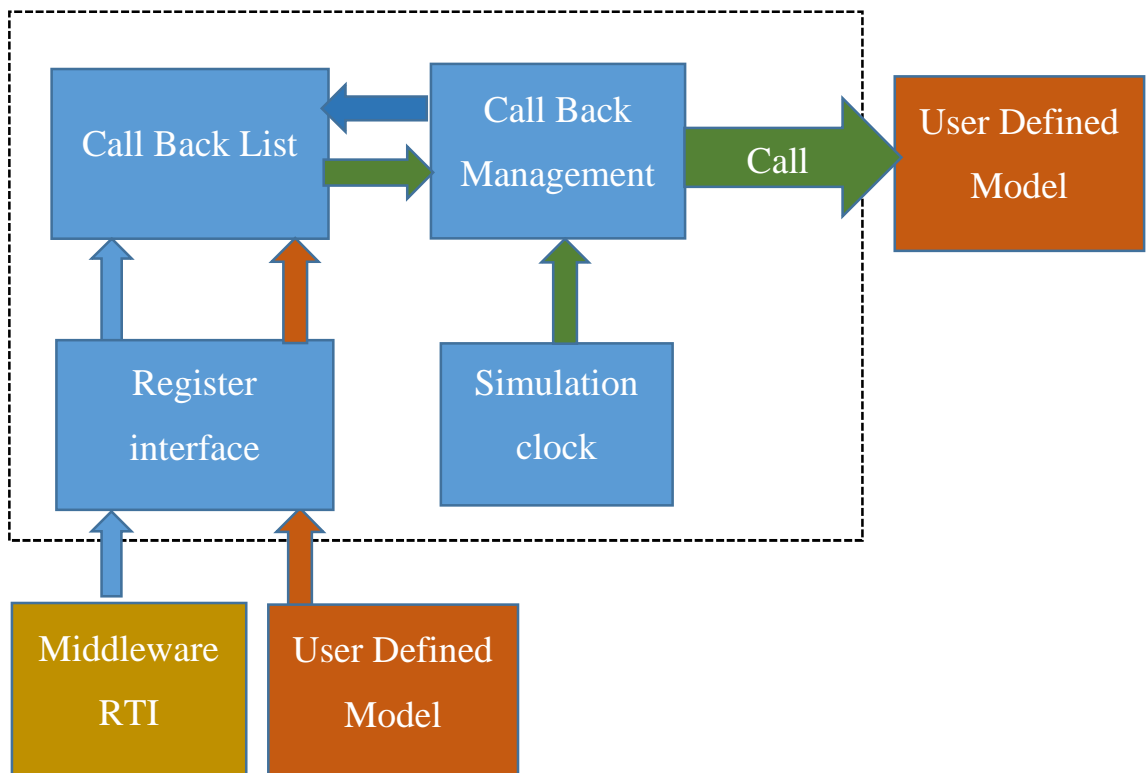

3 RTI

3.1

RTI

HLA RTI,

RTI-Kit,

).

(

QoS
RTI-Kit,

RTI-Kit —

RTI

RTI-Kit,

RTI,

RTI-Kit

HLA RTI,

[4].

RTI.

RTI-Kit

SGI Origin,

Myrinet

, , '

IP.

RTI-Kit

RTI

DRTI (Detailed-RTI),

HLA (1.3).

3.0 Federated-simulation Development Kit (FDK).

3.1

- RTI-Kit.

RTI-Kit

RTI-

Kit,

RTI-Kit.

MPI.

RTI-Kit

(IPAQ).

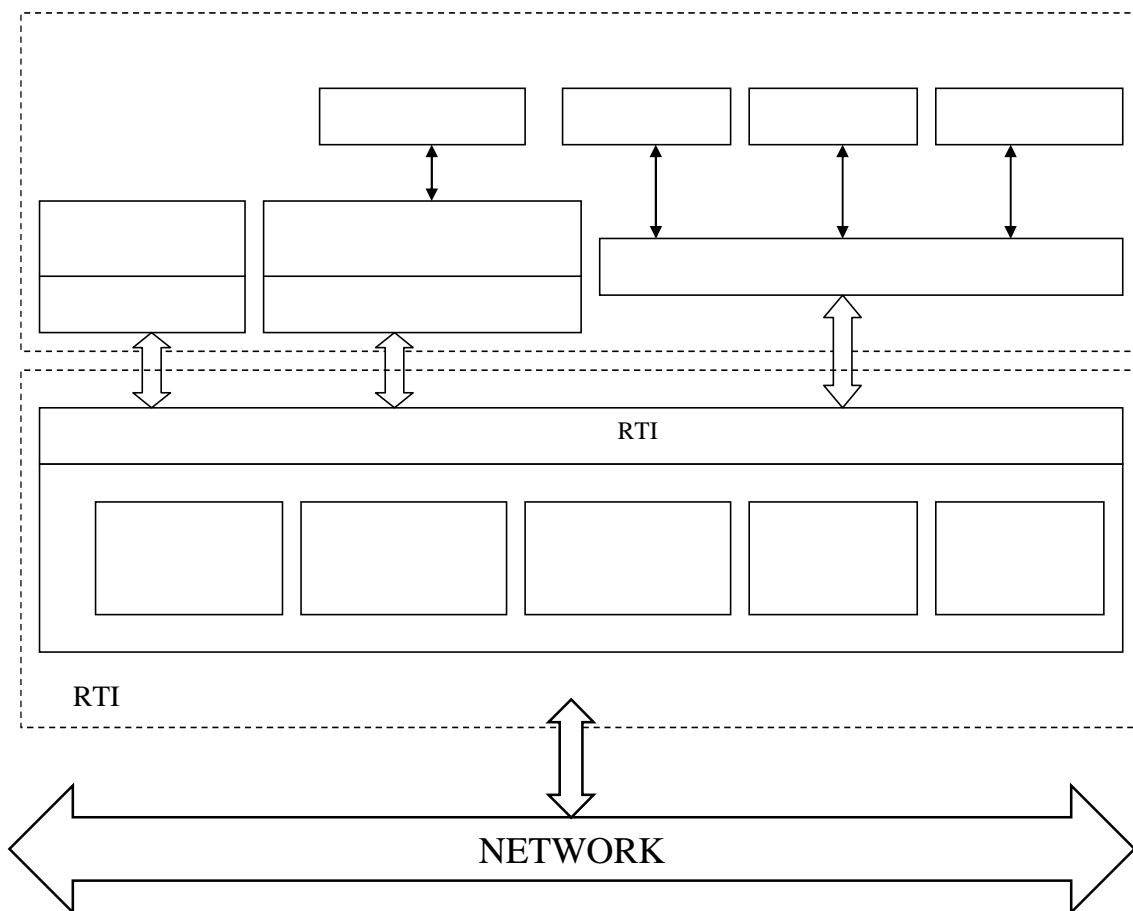

3.1 -

HLA

3.2

RTI-Kit

HLA RTI

RTI-Kit

HLA: . . . ;

() (tick()).

RTI,

RTI

RTI

RTI-Kit MCAST

.MCAST ECho,

Georgia Tech.

ECho — ,

[9].

TCP, ,

(, ATM UDP) QoS. ECho

, Linux, UNIX

Microsoft Windows. Echo

- .

MCAST, Echo. MCAST

, ,

, RTI-Kit MCAST. Connection Manager

(CM), Echo, API,

MCAST , CM

. ECho
CM

Solaris Windows)

(, Linux,

. MCAST

ECho/MCAST,

DRTI

RTI

RTI

RO (').

RO

ÒticklessÓ.

Pentium II 300

,
Redhat Linux 7.1.

Fast Ethernet 100 /

TCP

(

)

128

(RTT)

3.2.

Round Trip Delay for Synchronous and Asynchronous Delivery

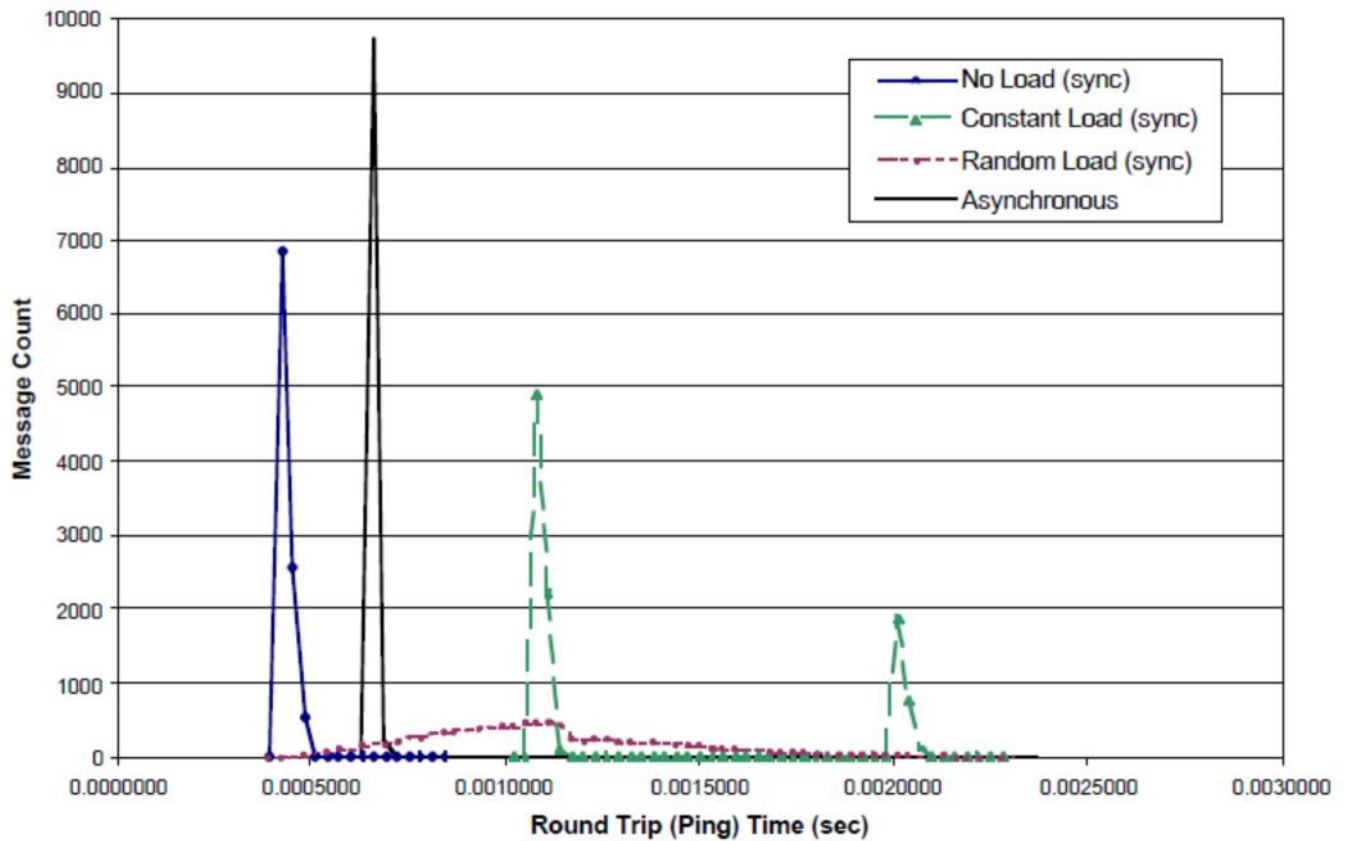

3.2 -

```

; tick()
tick()
tick().
10 000 RTT
DRTI ECho. DRTI
3.2
0,39 0,43
RTT
tick().
[3]

```

, RTI , (1)
, (2)

, - ,

, , —

(LBTS) -

, ;

. LBTS , -

(, , ,

) LBTS

, .

, LBTS,

,
().

RTI

. RTI

[3].

tick(). ,

tick() .

RTI-Kit LBTS

,
: 1) , 2)

LBTS.

LBTS ,

RT.

, , LBTS ,

;

LBTS,

LBTS.

RTI

LBTS

LBTS,

LBTS

LBTS.

3.3

LBTS.

30

Linux,

TCP

Ethernet.

2

(

)

LBTS

0,25

(

)

3,

RT-LBTS.

LBTS

3.3 –

LBTS,

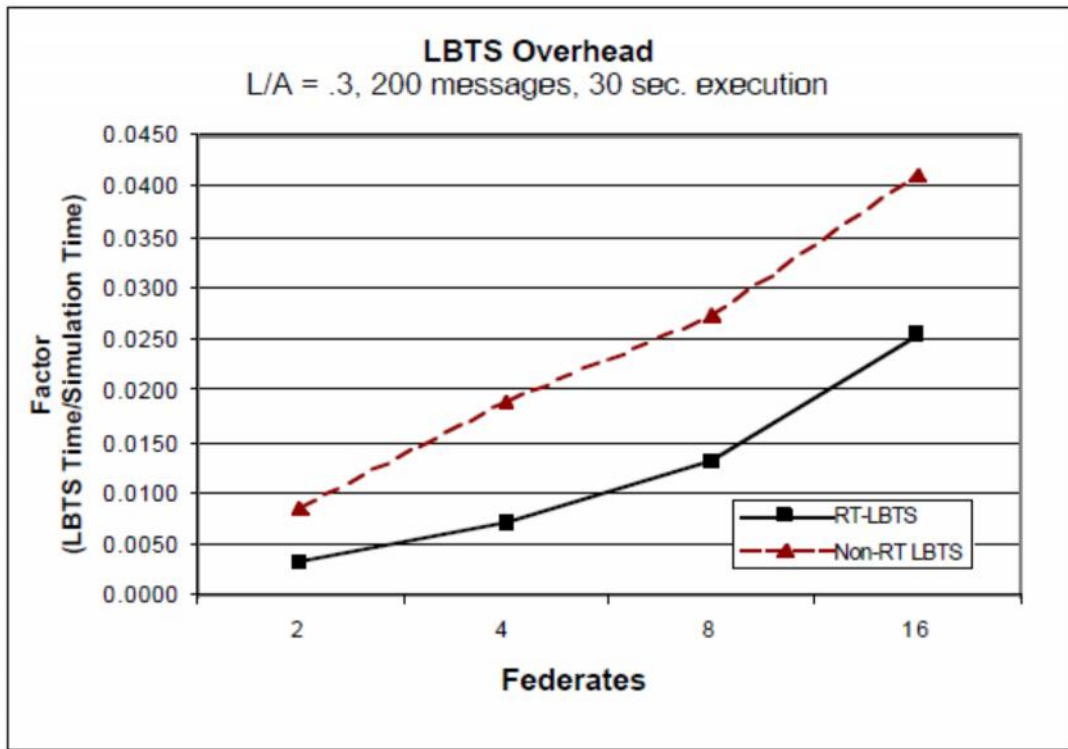

3.3 –

RT-LBTS

LBTS

RT-LBTS

119

LBTS (

LBTS),

LBTS

237

431 350

RT LBTS,

3.4

HLA

HRT RTI

HLA IFSpec.

HRT

RTI

.HLA

. HLA IFSpec

RTI.

RTI

QoS.

RTI

QoS

IFSpec, RTI

RTI

QoS

(-).

RTI

Ambassador

tick() (invokeCallbacks()

IEEE 1516), RTI IFSpec

RTI.

tick()

(1)

RTI,

RTI Ambassador

Federate Ambassador.

, HRT RTI

RTI.

RTI

[7].

RTI

HRT. , HRT RTI

RTI

,

.

,

.

HLA

RTI , .

HLA RTI

,

.

.

,

.

,

.

,

,

,

,

.

,

HRT

RT-

LBTS,

HRT

RTI.

RTI

HRT.

RTI

QoS,

,

RTI

.

,

,

RTI

.

HLA.

RTI

.

LBTS

RTI

RTI

HLA

QoS

HRT RTI.

, RTI

(,

).

1. Fujimoto, R. et al., Design of High-Efficient RTI Software, in Proceedings of Distributed Simulation and Realtime Applications, August 2000 (DIS-RT-2000), pp. 18–19, 2001, p. 82.
2. Fujimoto, R. et al, Design of High-Efficient RTI Software, in Proceedings of Distributed Simulation and Realtime Applications, August 2000 (DIS-RT-2000)
3. McLean, T. and R. Fujimoto, Repeatability in Real-Time Distributed Simulation Executions, in Proceedings of the 14th Workshop on Parallel and Distributed Simulation, 2000.
4. Fujimoto, RM and P. Hoare, HLA RTI Performance in High Speed LAN Environments, in Proceedings of Fall Simulation Interoperability Workshop. 1998:
5. Ferenci, S. and RM Fujimoto, RTI Performance on Shared Memory and Message Passing Architectures, in Proceedings of the Spring Simulation Interoperability Workshop 1999. 1999:
6. Lamport, L., Time, Clocks, and the Ordering of Events in a Distributed System, Communications of the ACM, 21, 7, pgs. 558-565, 1978.
7. Fujimoto, R. et al., Design of High-Efficient RTI Software, in Proceedings of Distributed Simulation and Realtime Applications, August 2000 (DIS-RT-2000), pp. 18–19, 2001: 01S-SIW-007.
8. Tacic, I. and RM Fujimoto, Synchronized Data Distribution Management in Distributed Simulation, in Proceedings of the 12th Workshop on Parallel and Distributed Simulation. 1998.
9. Fujimoto, R. et al., Design of High-Efficient RTI Software, in Proceedings of Distributed Simulation and Realtime Applications, August 2000 (DIS-RT-2000), pp. 18–19, 2001. ECho, <http://www.cc.gatech.edu/systems/projects/ECho>, 2000

10.
CORBA . Real-Time Systems, The International Journal of Time-Critical Computing Systems, , 20(2), 2001.
11. Schmidt, DC and F. Kuhns, An Overview of the Real-time CORBA Specification, IEEE Computer Magazine, Special Issue on Object-oriented Real-time Computing, June 2000.
12. O’Ryan, C. and DC Schmidt and JR Noseworthy, Patterns and Performance of a CORBA Event Service for Largescale Distributed Interactive Simulation. , CRL Publishing, 2001.
13. Brutzman, Don, Zyda, Michael, Watsen, Kent, Macedonia, M. Virtual reality transfer protocol (vrtp) Design Rationale," Proceedings of the IEEE Sixth International Workshop on Enabling Technologies: Infrastructure for Collaborative Enterprises (WET ICE '97) , « », 18-20 1997 ., .179-186.
14. « (CBone),» 15- DIS,
15. , "Bamboo - ", Proceedings of VRAIS 98, 16 - 19 1998, , .252-259.
16. Wuerfel, Roger, « HLA DIS », 98S-SIW-042, Proceedings of Spring Simulation Interoperability Workshop, Orlando, FL, 1998.
17. Zhao, H. and ND Georganas, ÒHLA Real-Time ExtensionÓ Proc 5th IEEE DS - RT '2001 , IEEE , 2001 .