

-  
\_\_\_\_\_  
( )  
\_\_\_\_\_  
( )

\_\_\_\_\_  
( )  
\_\_\_\_\_  
\_\_\_\_\_  
\_\_\_\_\_  
( )

:  
\_\_\_\_\_  
II , \_\_\_\_\_ -18-2  
\_\_\_\_\_  
( , )

\_\_\_\_\_  
123 - ' \_\_\_\_\_  
\_\_\_\_\_  
( )

\_\_\_\_\_  
\_\_\_\_\_  
( - - )

\_\_\_\_\_  
( )  
:  
\_\_\_\_\_  
( , , )

\_\_\_\_\_  
( ) \_\_\_\_\_  
( , )



5. ( ) \_\_\_\_\_ . -12 . . 4

---



---



---



---



---



---



---



---

6. .1) ( , , , , ) ,

	( , , , , )		

1.	.	31.03.20-13.04.20	
2.	.	14.04.20-20.04.20	
3.	.	21.04.20-29.04.20	
4.	.	30.04.20-03.05.20	
5.	.	04.05.20-05.05.20	
6.			
	.	06.05.20-11.05.20	
7.			
		12.05.20-13.05.20	
8.		14.05.20-15.05.20	

30 2020 .

\_\_\_\_\_ ( )  
 | \_\_\_\_\_ ( ) \_\_\_\_\_ ( , , , ) . .

: 75 ., 16 ., 2 ., 25

VPN, USB-

( )

USB-

## ABSTRACT

Master's thesis: 75 pages, 16 figures, 2 appendices, 25 sources.

VIRTUALIZATION, INTERFACE, CONTROL METHOD, SERVER, VPN, USB PORT, NETWORK.

The major goal of this thesis is intruder analysis and development of a new method for remote control of scientific tools with virtualization of interfaces with failure of a network component on a platform of virtual (overlay) computer networks.

In the course of performance of the certification work, the current status of the task of organizing remote access to remote devices was analyzed, a new method of remote control of scientific tools with virtualization of USB-interfaces was proposed, a computer system was implemented, where the developed method was implemented, the efficiency of the remote access system's reliability was evaluated remote devices.

		,	,	,	
		.....			7
		.....			8
1					
				.....	10
1.1		.....			10
1.2				.....	15
1.3		.....			24
2					
		.....			25
2.1	USB-	.....			25
2.2		.....			30
2.3		.....			34
3				.....	40
3.1	-	.....			40
3.2				.....	45
4					
				.....	56
		.....			61
		.....			62
				.....	66
	VPN-	.....			73

, , ,

-  
-  
- , -  
-  
-

API – ( ., Application Programming Interface)  
JSON – ( ., JavaScript Object Notation)  
SSL – ( ., Secure Sockets Layer)



,  
 .  
 ,  
 ,  
 IP- , VPN- :  
 ,  
 VPN-  
 IP- .  
 ,  
 ( ) , .

1

1.1

,

,

,

.

,

[1, 2].

,

,

,

,

,

.

-

,

,

,

[3, 4],

,

,

.

.

:



,  
 ,  
 ,  
 , « »,  
 ,  
 ,  
 « »  
 :  
 - — « »,  
 ;  
 - — ,  
 « »;  
 - — « »;  
 - —  
 , .  
 - « »  
 « » ,  
 :  
 - — « »;  
 - —  
 ;  
 - —  
 , , ,  
 , IP- ;  
 - - ,  
 , , ,  
 .

,  
 :  
 - « », - ,  
 ;  
 - ;  
 - « », ;  
 , « »  
 ;  
 - ,  
 ;  
 -  
 « ».  
 .  
 ,  
 : - , ( )  
 [7].

1.1.

Solaris  
 Linux Sun Java SE Sun Ray Server Software.  
 dtlogon,  
 ;  
 dtinfo. dat; dtautologin,  
 ; java-  
 de\_shell.jar.  
 dtautologin X Window System

, , X Window System  
 .

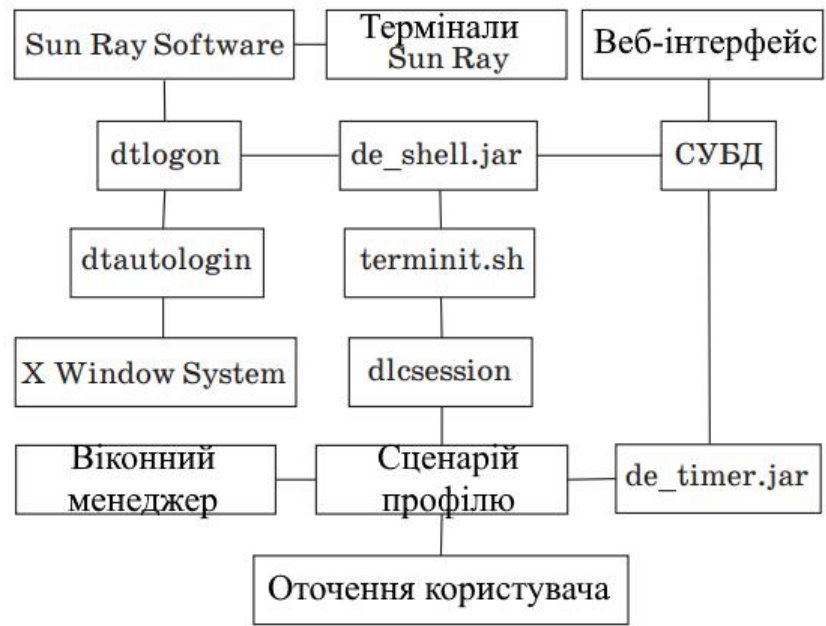

1.1 –

de\_shell.jar  
 config.cfg , «  
 – », logusers.dat  
 terminit.sh.  
 terminit.sh dtinfo.dat logusers. dat  
 , ,  
 dlcsession ,  
 .  
 dlcsession  
 , ,  
 java- de\_timer.jar,  
 , . ,  
 , de\_timer.jar  
 .  
 , ,  
 .



TCP/IP

Java,

Java-

VNC  
RFB),

(remote framebuffer,

VNC

Palm, HP Jornada, Windows CE,

Newton

Windows

Windows

Windows-

Home

TeamViewer.

Internet

NAT

TeamViewer

IP-

. TeamViewer

Windows Linux [9, 10, 12-13].

Windows

LiteManagerTeam

LiteManager.

Pro Free.

Free

Pro

LiteManager

UltraVNC

VNC.

VNC

AES

RC4,

NTLM

Active

Directory. UltraVNC

Linux,

Linux

Windows

SSH

VNC.

Linux-Windows

VNC

Windows

Linux-

VNC-

Gtk VNC Viewer.

Linux-Linux

VNC

VNC-

Synergy.

<<

>>

VNC-

ssh-

Putty

Xming

Linux,

Windows.

Linux

Linux,

Windows.

Putty

Xming

Linux Windows

Linux (Putty), Linux

VNC-

NX.

NoMachine,

FreeNX,

GPL.

VNC, NX

Unix, Windows Mac OS.

NX-

- Citrix;
- Microsoft;
- X Window System.

Microsoft Windows Server 2016 R2

Windows Server 2016.

Microsoft Windows «  
» (Remote Desktop),

Remote Desktop Protocol (RDP) TCP- 3389.

Windows Server 2016

(  
).

Windows Server

2016

- RemoteApp Windows Server 2008

RemoteApp

RemoteApp

RemoteApp.

NLB,

DNS,

RDP-

Hypertext

Transfer Protocol Secure (HTTPS),

VPN.

.  
 .  
 VDI VDS.  
 - ,  
 ( , , )  
 , ( , ).  
 ,  
 , -  
 ( , , , . .) -  
 ( , , ).  
 ,  
 .  
 :  
 - (VDI) - ,  
 (Windows 10 . .)  
 -  
 (Citrix XenDesktop, VMware View, Microsoft VDI, Quest  
 vWorkspace);  
 - (Remote  
 Desktop Services Host (RDSH) / Terminal Services (TS)) -  
 ,  
 ( ,  
 ).  
 - Citrix XenApp, Microsoft RDS, Quest vWorkspace;  
 - (Blade PC) -  
 (  
 ) - , ,  
 .  
 - Citrix HDX 3D Pro + Dell R5500, VMware View + Dell R5500;

(Application Virtualization) –

: Microsoft

App-V, Citrix XenApp, VMware ThinApp;

«VDI-» ( 1.2):

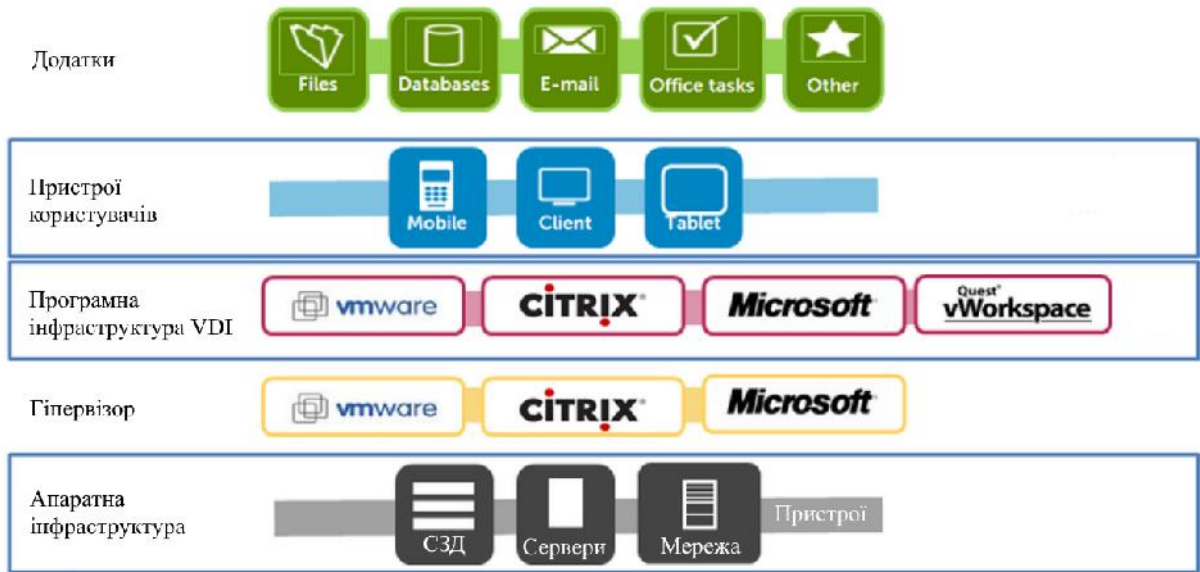

1.2 – VDI

(Microsoft, VMware, Citrix),

- VDI\TS -  
 ,  
 ;  
 - - ( , ,  
 . .),  
 ;  
 - - - , Microsoft App-V  
 VMware ThinApp.  
 ,  
 ,  
 , USB.

1.3

, :  
 ,  
 ,  
 ,  
 ,  
 ,  
 ,  
 ,



USB-

- ; -

USB-

USB

(  
) USB-

USB-

USB

AVR –  
2K.

MEGA TINY FLASH-

USB-2

«Low speed», – 1,5 / .

1.6 FLASH-

USB

AVR, –

USB-

AVR.

USB

AVR

Atmel

[14] Objective Development [15].

USB

D+ D-

(

ATMega16)

USB

2.1.

D

R3,

/

USB

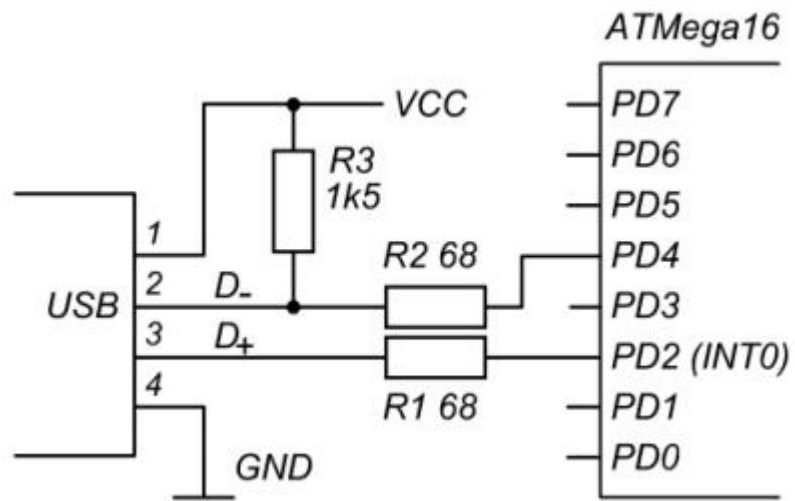

2.1 –

USB

USB-

2.1,

USB.

USB

3.0-3.6 ,

ATMega16

4.5-

5.5 .

USB.

5 ( ,

). - ,

USB.

c

[14] 2.2.

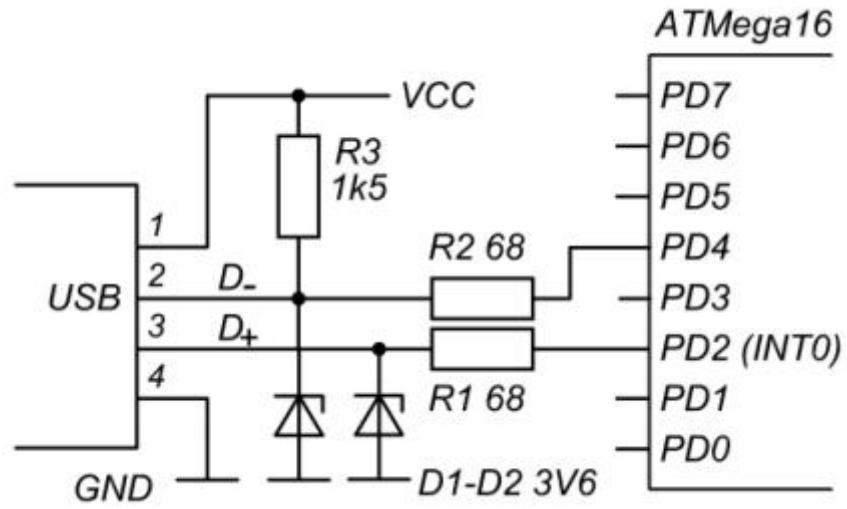

2.2 -

USB

INT0

1M

« »

D+.

USB

[16]. ,

USB

USB

USB

USB- . , Custom class device, Standard HID class device,  
Custom HID class device CDC class device.

USB-

USB-

USB-

USB-

USB

USB-

USB-

USB-

2.2

VPN- ( 2.3) [12].

$n$  :  $(n+1)$ -

( , 3G- );

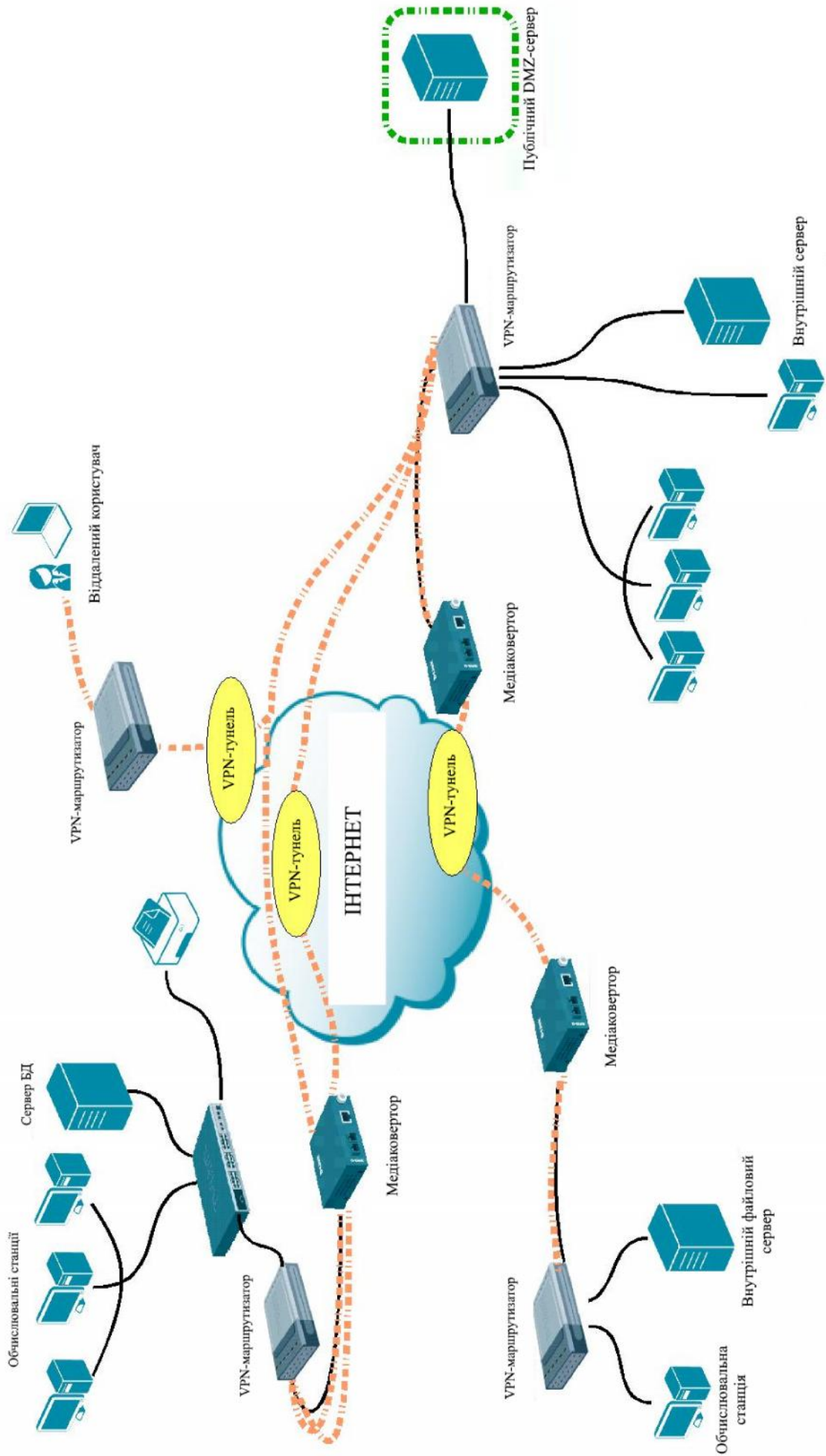

( , ), USB- (n+2)- ' .  
 (N+I)- ' , ( );  
 - - , IP-  
 VPN;  
 - , , .  
 -  
 / USB- .

1. / IP-  
 VPN- .  
 PPTP.

( . ) , ( , , ,  
 PPTP, . , ,  
 OpenVPN.

2. ' , , ,  
 (3G- ), VPN- . , ,  
 ( ) IP- , ,  
 VPN- , ,  
 IP- .

3. (n+1)- ' VPN-  
 . ,  
 IP- , IP- ,

VPN-  
OpenVPN.

4.

VPN-

VPN-

( G- ) -

( )

VPN-

[13].

VPN-

VPN-

$$\Psi = D\ell(2S + (2i - 1) \sum_{i=1}^{\log_2 S} 2^{i-1}), \tag{2.1}$$

: D -

VPN- (

);

S -

;

ℓ -

’ , ’ , ’ ,  
’ « - » ( )

VPN- ,  
:

$$\Psi' = D(1 + \log_2 S + \sum_{i=1}^{\log_2 S} 2^i + \ell S), \tag{2.2}$$

,  
,  
VPN :

$$\theta = D(\ell S - YW), \tag{2.3}$$

: Y – ,

IP- ;  
W –  
[13].

2.3.

2020

,  
,  
[14].  
:  
,  
,  
- ,

3G-

; -

IP-

;

,

( , , , . .);

,

,

.

:

,

( , )

,

,

(

,

-

,

,

,

,

,

,

.

,

,

:

;

,

.

,

,

,

,

IP-

,

,

.

.

,

,

VPN-

.

,

-

IP-

,

IP-

(256) , ( IP- , - IP- VPN- ). , - , VPN- , IP- . , , - , VPN- , IP- , VPN- - . , VPN- IP- , IP- , , - , .

2.4.

VPN- , , - , . , - , . ( 10 ) . , , .

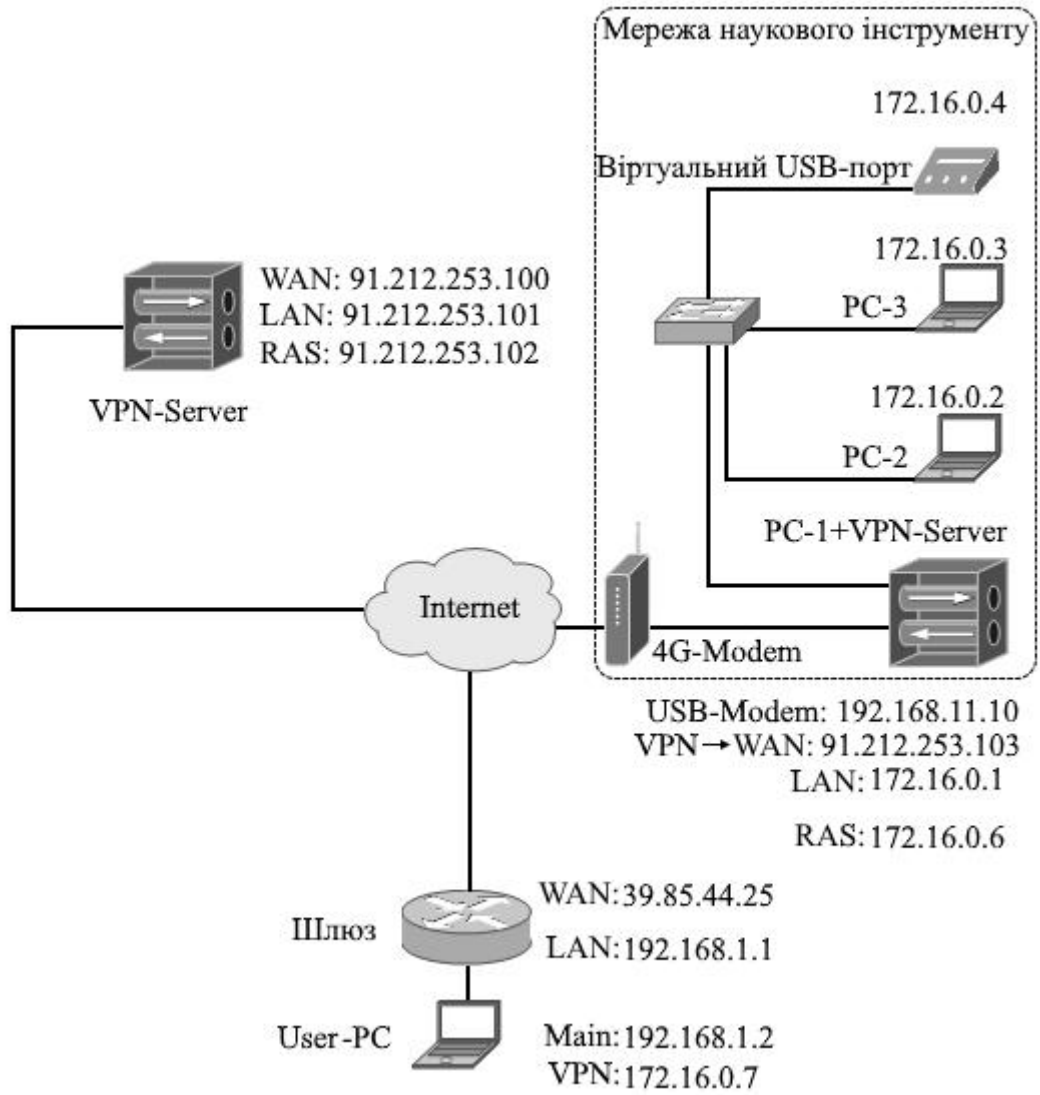

2.4 –

IP-

USB

USB-

USB/IP.

USB-

USB-

USB / IP

«USB I/O

»

TCP/IP

VPN- IP-

IP-

2.5.

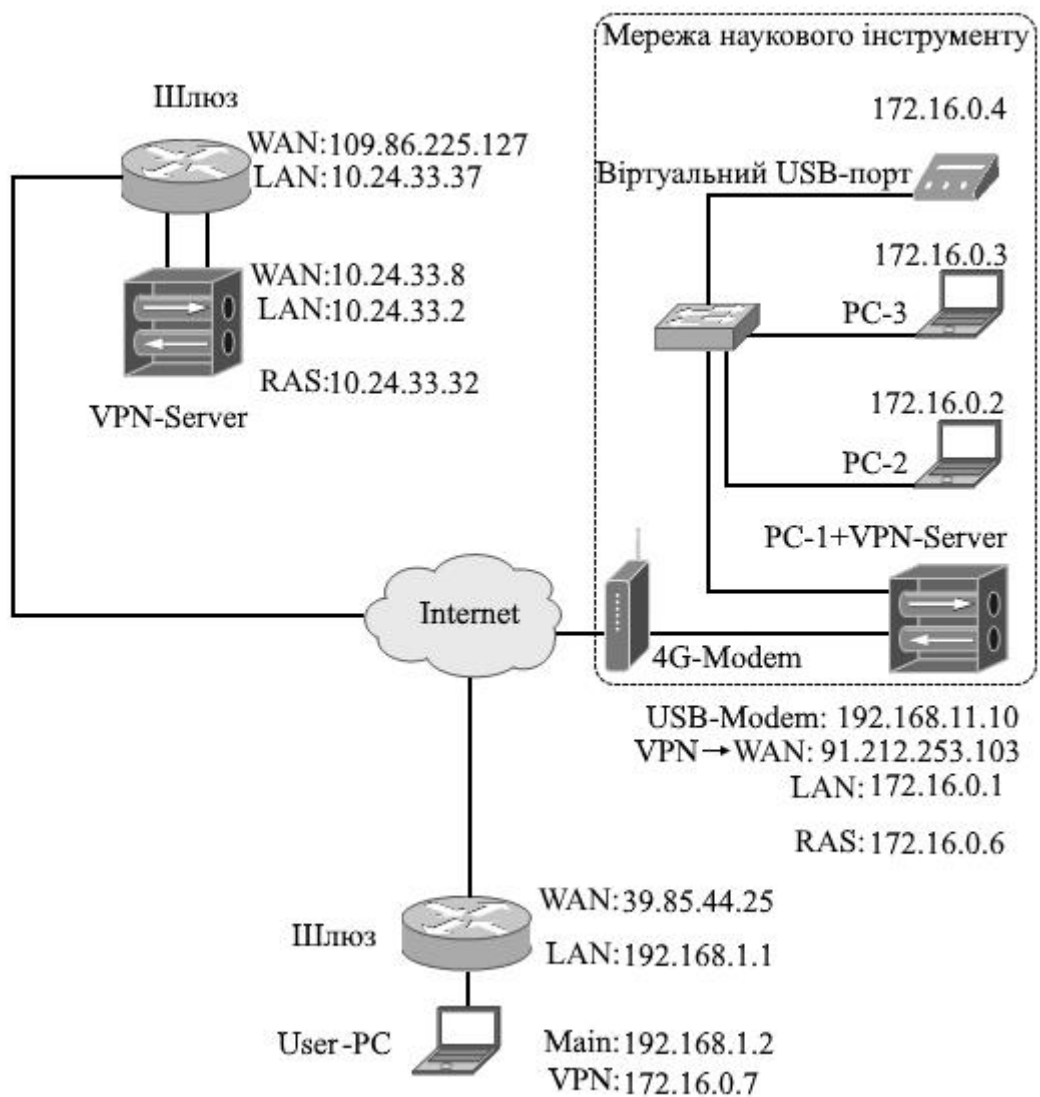

2.5 –

IP-

VPN-

VPN-

VPN-

« » IP-

IP-

VPN-

VPN-

VPN- '

IP-

109.86.225.127.

10.24.33.33,

IP-

172.16.0.0/24

3

3.1

, - , - , ,  
 .  
 . , - ,  
 , - ,  
 . , ,  
 , , , - .  
 :  
 .  
 ,  
 .  
 , -  
 . ,  
 . ,  
 , , .  
 . ,

( ) , , .

2 :

;

Speed – / ;  $s_1, \dots, s_M$  –

Power – ;  $\mu_1, \dots, \mu_N$  –

[12, 13, 14].



$3xN, N - . C$

, :

$$\mu_i, i, F_i(\mu_{i-1}), \tag{3.1}$$

$F_{i-1}$  ;  
 $\mu_{i-1}$   $I$ ;  
 $i-1$   $I$ ;  
 $i(y)-$  ;  
 $i-$  .

$$F_i(\mu_{i-1})$$

$N-$  .

$n-$

(n ):  $F_i(\mu_{i-1})$

$$i) = \mu_1^{i^1+\dots+n} \mu_{i^1+n+1}^{i^1+\dots+2n} \mu_{i^n}$$

$F_{i-1}$

[15].

,

[13].

,

$- Max \mu, Min \mu$  )

(  $- Max, Min$  ).

$Max, Min, Max \mu, Min \mu$  .

,  $F(x_{max}) Extr(\mu_i), Extr(i)$

$i,$

(Speed, Power1 ... PowerM)

$$Extr(\mu_i), Extr(i)$$

ANOVA.

« »

ANOVA

( 3.1).

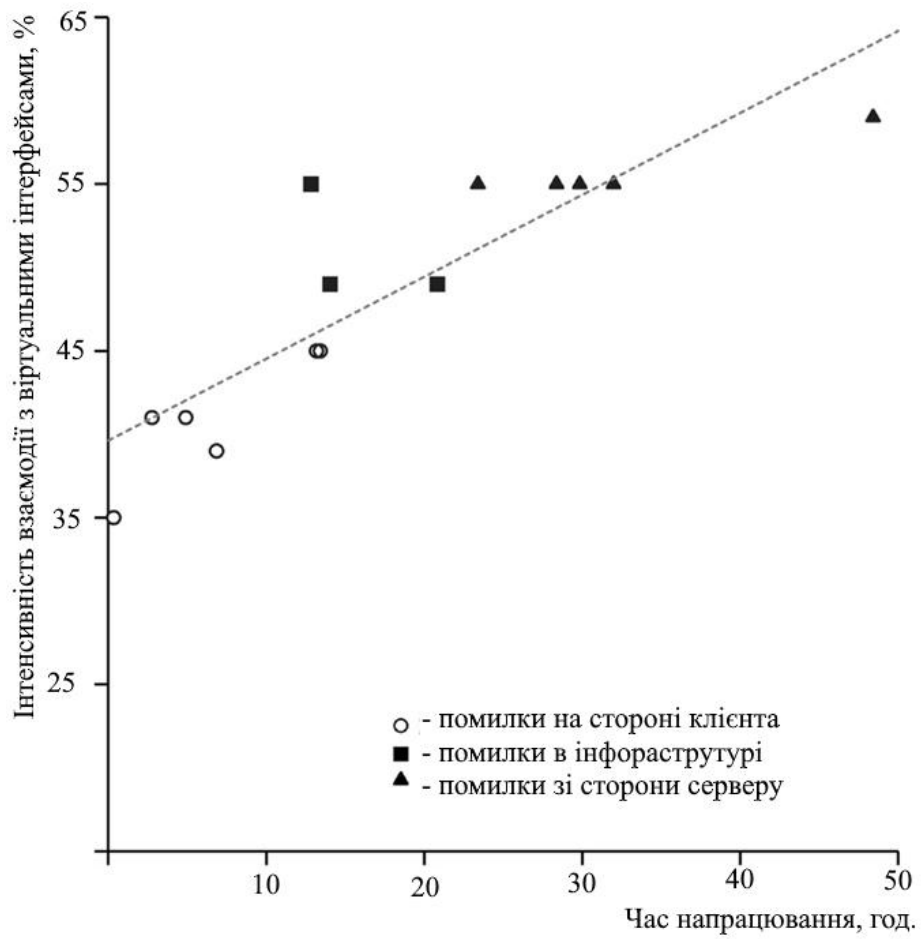

3.1 –



$$\sum_{b_b \in E_b} b_b(u,v) \rightarrow \min \tag{3.2}$$

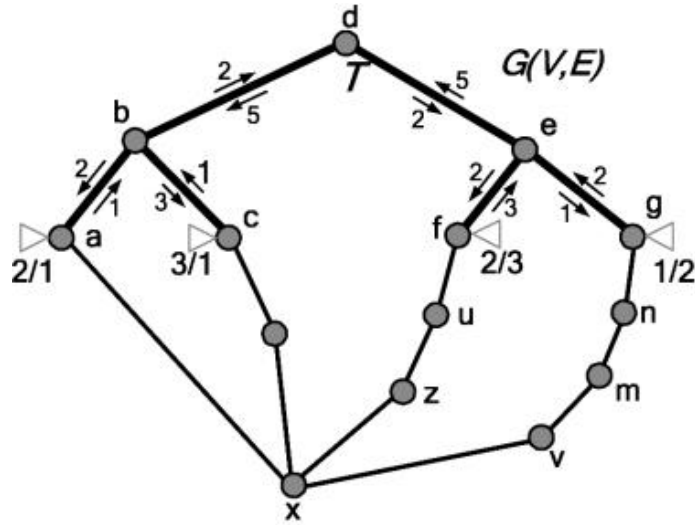

3.2 – VPN-

$G$   $w:E$   $R^+:($   $G' \subset G.$   $(NP-complete)$   
 $A \in G,$   
 $AUG'$   $k-$

3.3.

$AUG' -$

VPN

VPN T 2- ' Tb.

T VPN Tb

2- '

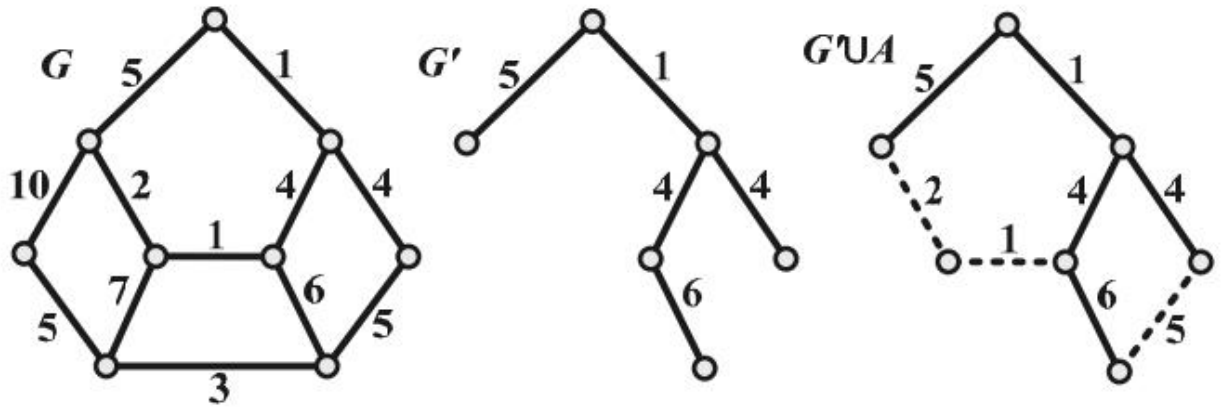

3.3 –  $G'$   $A$   $G$

$A \subseteq E(G)$ ,  
 $-$  ,  $AUG$  , ;  
 $-$   $\{f\} \in A$  ,  $e \in T$ ,  
 , VPN.  
 $T$  ,  
 $G$  (  $T$  , ) .

$G$  , [13]:  
 $G''$ ,

$T$ . [14]

1.  $G'$  4.
2.  $G''$  2.
- 2.1.  $T$ .
- 2.2. .
3.  $G''$ .
4.  $A''$   $A$ .

:

[14] 2-

$T,$   $T,$

[13].  $(u,v)$   $T$

:  $T(u, v) -$   $u$   $T(v, u) -$   $v.$

$(u, v) -$  VPN

$T(u,v):$

- $T(u, v) > T(v, u),$   $(u, v)$   $u$   
 $v;$
- $T(u, v) < T(v, u),$   $(u, v)$   $v$   
 $u;$
- $T(u, v) = T(v, u)$   $(u, v)$

$T.$

VPN ( « » « » ,

VPN).

:

- ( VPN);
- :

$T$

VPN

:

1.

1.  $G':G$   $G'.$

2.  $G'' : G' \quad G''.$

2.1.  $T.$

2.2.

2.3.  $G'' \quad G''$

3.  $G''.$

4.  $A'' \quad A.$

2. :

1.  $G' : G \quad G'.$

2.  $G'' : G' \quad G''.$

2.1.  $T$

$T$

2.2.

2.3.  $G'' \quad G''$

3.  $G''$

4.  $A''$

$A$

VPN

(  
).

(  
).

.3.2.

1.  $G':G \quad G'$ .

$G'$

$T$ .

-  $G-T, \quad G' \quad u \quad v \quad T \quad (u, v)'$ .

$G', \quad 3.4.$

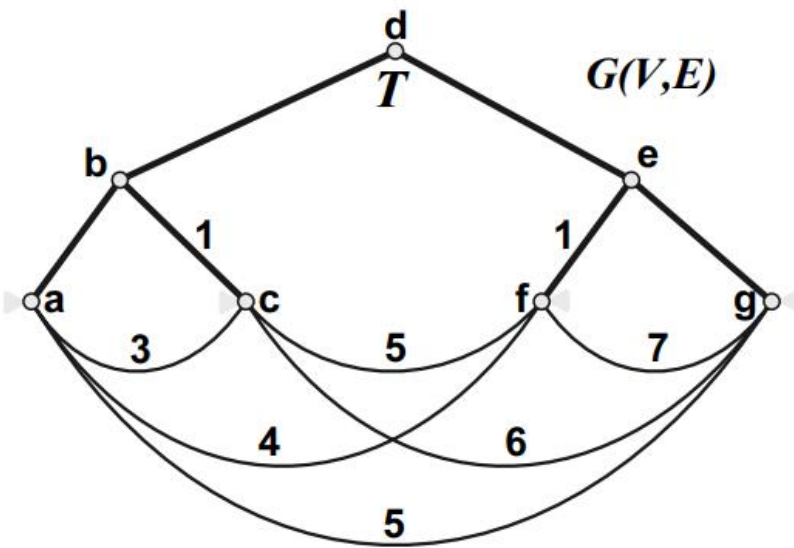

3.4 -  $G$

2.1.  $T$

$T$

VPN.

$e ( \quad 3.5),$

$b.$

2.2.

$u \quad v$

$lca(u, v)$

.

.

$b$

$(a, c), e$

$(a, f), (a,$

$g), (c, f), (c, g) (f, g) ($

3.5).

$e$

$(f, g), b$

$(a, c), (a, f), (a, g), (c, f) (c, g).$

[18].

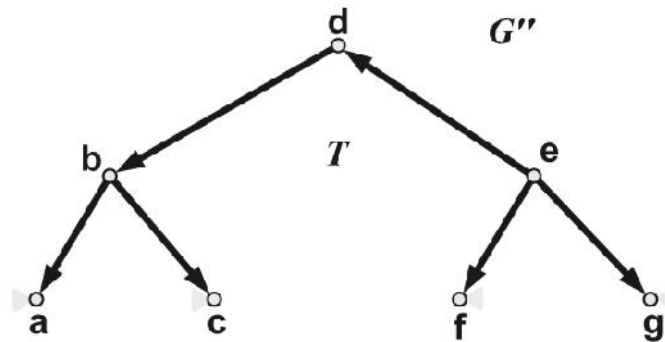

$e$  – корінь вихідного трафіку  
 $b = lca(a, c)$   
 $e = lca(f, g), lca(a, f), lca(a, g), lca(c, f), lca(c, g)$

3.5 –

2.3.  $G''$ .

$G''$

$T$ .

$(u, v')$

$G-T'$

$T$

$u \quad lca(u, v): u_0=u, u_1, \dots, u_n=lca(u, v).$

$G''$

$(u_0, u_1), (u_0, u_2), \dots, (u_0, u_n).$

,

$(u_0, u_1),$

$(u, v')$

,

$(u_0, u_1), (u_0, u_2), \dots, (u_0, u_n)$

$T$ .

$T$   $v$   $lca(u, v): v_0=v, v_1, \dots, v_n=lca(u, v)$

$G''$

3.6.

$G''$

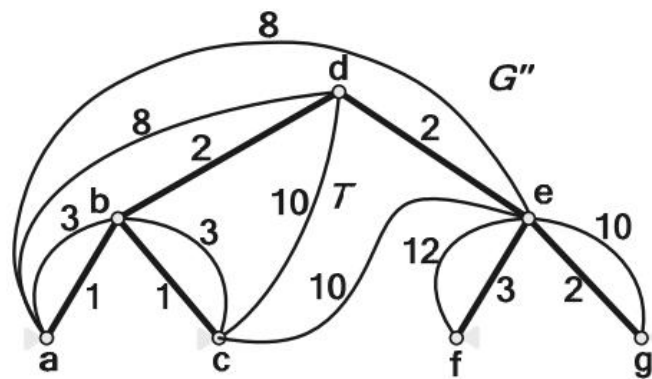

прямий трафік

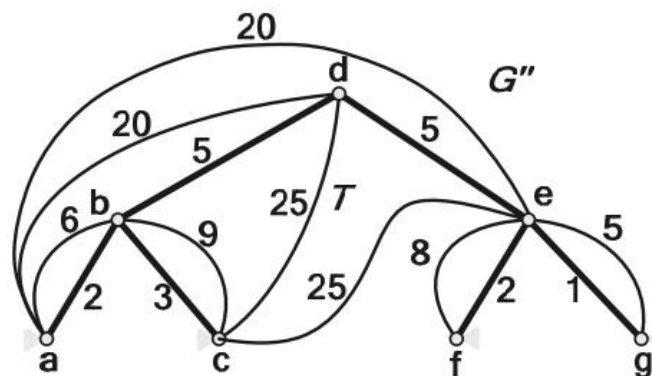

зворотній трафік

3.6 –  $G$

3.

$G''$

$G''$

[16].

0.

$(u, v)$ ”  $G''$ – ,  $u$   
 $v,$   $v.$  (  
 $)$   $G''.$

– ,  
 :

[21],

[22].

$A''.$

, 3.7.

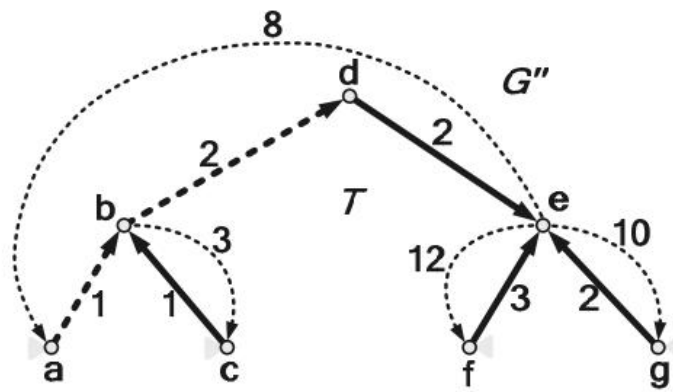

прямий графік

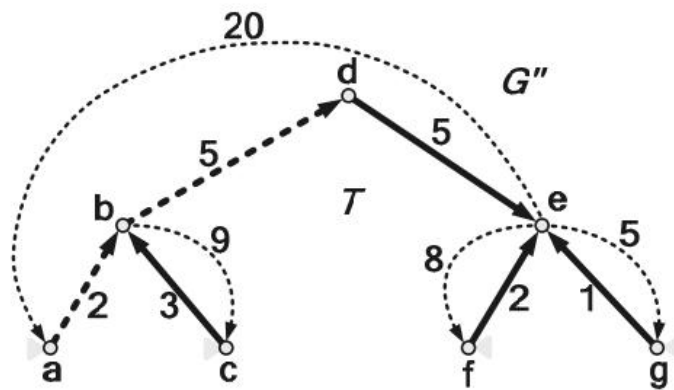

зворотній графік

3.7 –

A

4.  $A''$  .  
 $(u, v)'' \in A''$   $(u, v)'' \in G'' -$  ,  
 $(u, v) \in G -$  .  
 $(u, v)'' \in A''$  ( , )  
 $G-T -$  .  
 $(u, v) \in (G-T) -$   $v (u, v)'' \in A''$  ;  
 $(u, v)$   
 $G-T$   $(u, v) \in A''$  .

f,

3.8.

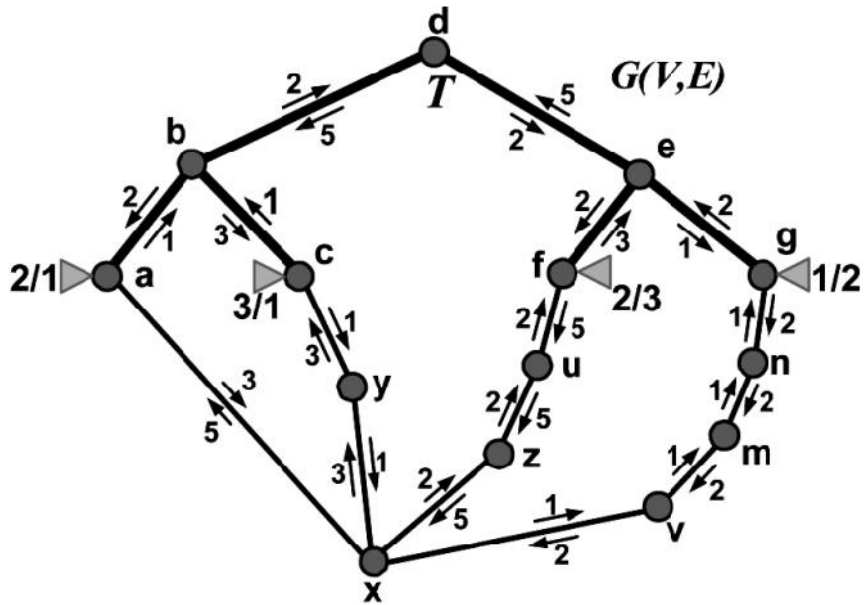

3.8 -

$G'$ .

$G$ ,

,

.

,

,

VPN

.

,

.

VPN.

4

$$\begin{aligned}
 & G(V, E), \\
 & \cdot \\
 & , \\
 & G^{VPN}(V', E'), V' \subseteq V, E' \subseteq E, \quad G^{VPN}(V', E') \\
 & \cdot \\
 & , \quad k \quad F \in E' - \\
 & , \\
 & - \quad F \quad R \in G(V, E) \setminus F \\
 & \quad b(u, v) \quad , \\
 & \quad P \in (G^{VPN} \setminus F) \cup R. \quad , \\
 & \cdot \\
 & : \quad - \quad , \\
 & \quad : \quad P \in (G^{VPN} \setminus F) \cup R \quad , \\
 & \sum_{(u,v) \in R} b(u, v) \rightarrow \min. \\
 & \cdot \\
 & \quad T(V', E') \in G. \quad , \\
 & \quad , \quad b(e). \\
 & - \\
 & \quad f \in G \setminus T \\
 & \quad , \\
 & \quad T.
 \end{aligned}$$

NP-  
 $A \subseteq E(G),$

$T \cup A -$  ;  
 $f \in A \quad e \in T, \quad T' = T - e + f$

$f$   
 $T,$   
 $A:$

$$w(A) = \sum_{f \in A} b(f) \tag{4.1}$$

3.2

[23]

$G(V, E), a T(V', E') \in G -$   
 $(u, v) \in T, \quad b(u, v).$

$$\sum_{(x,y) \in E} b(x,y) \rightarrow \min, \tag{4.2}$$

$b(x, y) -$  ,  $(x, y)$ .  
 $:$   
 $(x, y) : p -$  .  
 $(u, v)$  ,  
 $(u, v) \in E'$  ,  
 $u < v, (x, y) \in Ep_{xy}^{uv} = \{0, 1\}$  ;  
 $:$   
 $(u, v) \in E'$  ,  $u < v$  ,  
 $(x, y) \in E$  ,

$$\sum_{(x,y) \in E \setminus \{(u,v), (v,u)\}} p_{xy}^{uv} - \sum_{(x,y) \in E \setminus \{(u,v), (v,u)\}} p_{yx}^{uv} = \begin{cases} 1, & x = u; \\ -1, & x = v; \\ 0, & \text{otherwise} \end{cases} \quad (4.3)$$

$$p_{xy}^{uv} + p_{yx}^{uv} \leq 1.$$

$:$   
 $(u, v) \in E'$  ,  $u < v$  ,  $(x, y) \in E$  ,  
 $(x, y) \quad d_{xy}^{uv} = b(u, v)$ .  
 $(u, v) \in E'$  ,  
 $u < v$  ,  $(x, y) \in E$  ,

$$d_{xy}^{uv} = \begin{cases} b(uv), & (x, y) \in E / \{T \cup EA(u, v) \cup EA(v, u)\}; \\ \min[B(x, y) - B(v, u), B(y, x) + B(v, u)], & (x, y) \in UT(u, v); \\ \min[B(x, y) + B(v, u), B(y, x) - B(v, u)], & (x, y) \in UT(u, v); \\ \infty, & \text{otherwise} \end{cases} \quad (4.4)$$

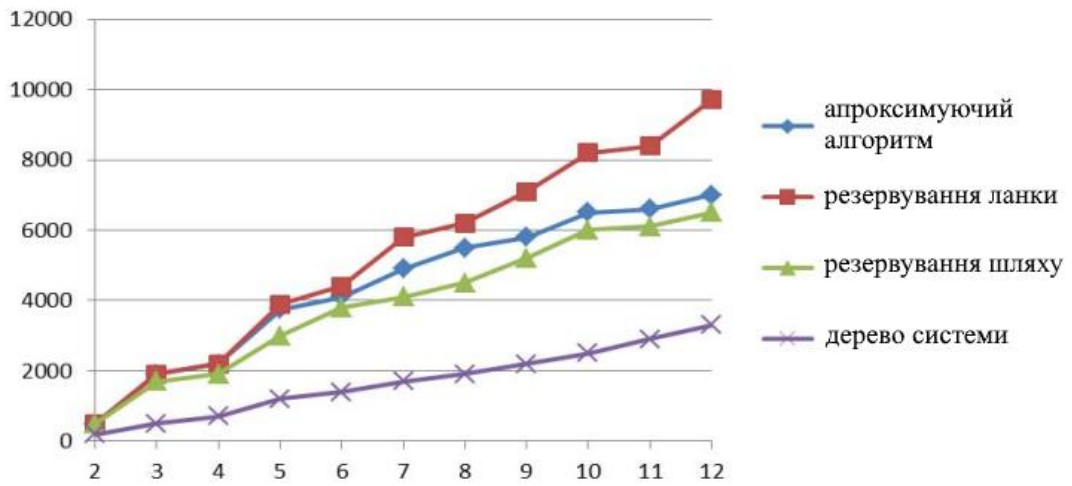

)

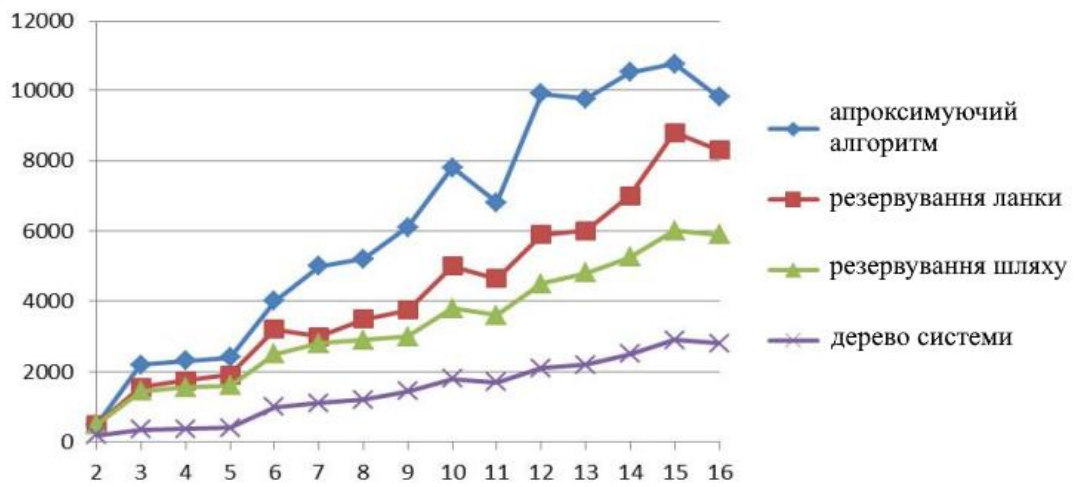

)

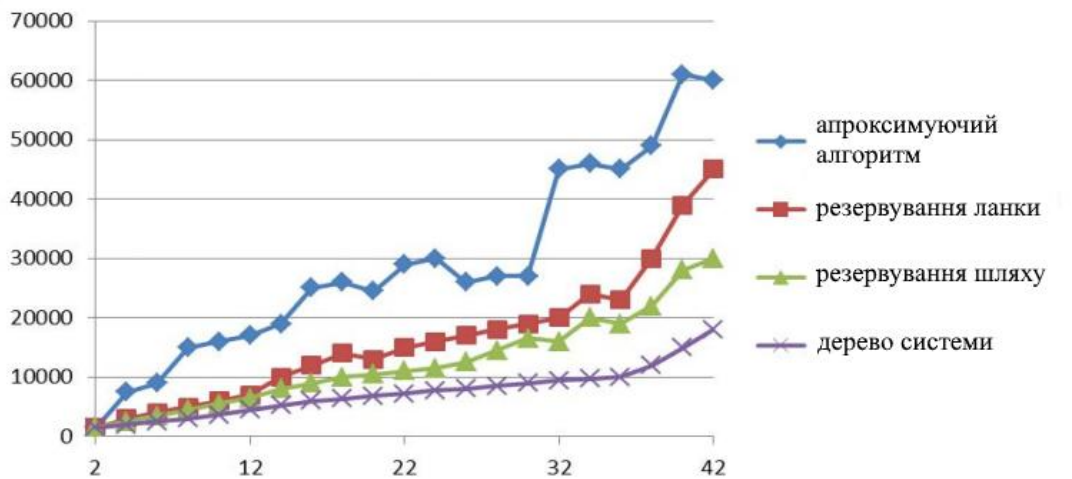

)

4.1 –

node Ring; )

NSFNET16; )

Euroring

: )

12-

,

,

.

### 4.1

,

.

,

«

»,

.

. :  
 - ,  
 USB- ;  
 - ,  
 VPN- ;  
 - -  
 . , ' VPN-  
 , ,  
 . , VPN-  
 , , VPN-  
 , ,  
 , ,  
 . , .



December). Overlay Network Infrastructure for Remote Control of Radio Astronomy Observatory. In 2019 IEEE International Conference on Advanced Trends in Information Theory (ATIT) (pp. 161-165).

8. V. Tkachov, M. Hunko, V. Volotka Scenarios for Implementation of Nested Virtualization Technology in Task of Improving Cloud Firewall Fault Tolerance. In Proc. 2019 International Scientific-Practical Conference on Problems of Infocommunications Science and Technology, PIC S and T 2019, 08-11 October 2019, Kyiv, Ukraine, pp. 769-773.

9. . . .  
 , / . . . ,  
 . . . , . . . - // ,  
 ' . - : , 2017. - . 2(42). - . 117-120.

10. . . .  
 // . . . , . . .  
 , . . . // -  
 « -  
 ». - - - - . - 26-27 2018 . -  
 . 19.

11. . . .  
 - / . . . , . . . //  
 . - : ;  
 : ; - : ; : « », 2018. - 14-16  
 2018. - . 78.

12. . . .  
 / . . . , . . . , . . . //  
 5 -  
 « », 13-15 2017 . - - -  
 - - . - 2017. - . 32.

13. . . . /  
 . . . , . . . // .

14. ... « ... », 2018. – 14-16 ... 2018. – .78.
15. ... / ... , ... , ... // ... - « ... » 12-13 2015 . – - - - - . – 46 .
16. Ghosh D., Kumar G. Low Power USB-Controlled Network Analyzer with Detector Compensation Technique //2018 IEEE MTT-S International Microwave and RF Conference (IMaRC). – IEEE, 2018. – . 1-4.
17. ... / ... , ... // ... . – .: ... , 2016. – . 5(142). – . 128-132.
18. - . . nvf //International Journal of Open Information Technologies. – 2018. – . 6. – . 11.
19. ... / ... , ... , ... // 4- - « ... » IPST-2015. – . – : « ... », 2015. – . 34.
20. Garg V., Kataoka K., Talluri S. S. R. Performance evaluation of wireless ad-hoc network for post-disaster recovery using linux live USB nodes //2015 IEEE 11th International Conference on Wireless and Mobile Computing, Networking

