

SECTION 16.

ELECTRONIQUE ET TÉLÉCOMMUNICATIONS

DOI 10.36074/logos-01.03.2024.043

TEMPERING OF STEELS WITH LOW-POWER LASERS OF THE UV RANGE

Yahyn Mykhailo¹

Academic supervisor: Afanasyeva Olha²

1. graduate of the Faculty of Economics

Kharkiv National University of Radio Electronics, UKRAINE

2. Associate Professor of the Department of Physical Fundamentals of Electronic Engineering, Candidate of Technical Sciences

Kharkiv National University of Radio Electronics, UKRAINE

A laser is a source of highly directional coherent electromagnetic radiation capable of achieving the maximum possible concentration of radiation energy in space, time and spectral range [1]. The basis of laser operation is the quantum-mechanical phenomenon of forced (induced) radiation, which can be pulsed or continuous. With pulsed radiation, extremely high peak powers are achieved, with continuous radiation, constant power is provided.

Laser industrial technologies are based mainly on the thermal effect of laser radiation on the material being processed, as a result of which, when certain temperatures are reached on the surface and in the volume of the irradiated material, various physical processes can develop [1, 2].

When a beam of laser radiation falls on the surface of a material, part of the radiation is reflected from it, and part passes deep into the material, being absorbed in it. The intensity of the absorbed radiation at the depth x of the processed material is determined by the Bouguer-Lambert law. Taking into account the reflection from the surface, it is equal:

$$I(x) = I_0 A \exp(-\alpha x), \quad (1)$$

where I_0 - the radiation intensity on the surface;

α - absorption coefficient;

R - reflection coefficient;

$A = 1 - R$ is the absorption capacity of the material.

The heat released in the material spreads deep due to thermal conductivity.

For laser hardening of precision parts, heating above the temperature of phase transformations, but below the melting temperature, i.e. hardening from the solid state, is of interest. This will allow, while preserving the geometric characteristics of the surface, to carry out the strengthening of steel products.

The threshold (critical) power density q_T for heating the surface to a certain temperature T can be calculated by the formula:

$$q_T = \frac{(T-T_0)\lambda\sqrt{\pi}}{2(1-R)\sqrt{\alpha\tau}} \quad (2)$$

where T_0 is the initial temperature of the material,

α – thermal conductivity of the material,

λ – the thermal conductivity of the material,

R – the reflection coefficient,

τ – the duration of exposure.

The reflectivity of metals, characterized by the value of the coefficient R , decreases with decreasing wavelength (Fig. 1), so the efficiency of heating metals increases when using a laser with a shorter wavelength. Therefore, the processing of metals using a Nd:YAG laser or a Nd:YVO₄ laser with a wavelength of $\lambda = 1.06 \mu\text{m}$ is more effective compared to processing with a CO₂ laser with a wavelength of $\lambda = 10.6 \mu\text{m}$ [2, 4].

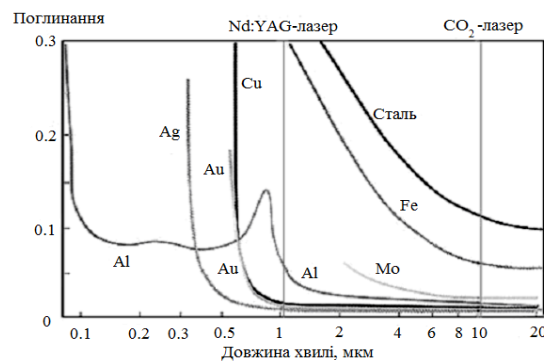

Fig. 1 **Absorption coefficient of some metals depending on the wavelength of radiation [3]**

To generate the third harmonic (355 nm) in a solid-state laser, nonlinear optical phenomena are used. The generation is implemented according to the following scheme: the main wavelength of 1064 nm excites the second harmonic (532 nm) on the first nonlinear crystal of potassium titanyl phosphate (KTiOPO₄). Then the radiation of the main and second harmonics is combined on the second nonlinear crystal, as a result of which the third harmonic with a wavelength of 355 nm is emitted at the output (Fig. 2).

SECTION 16.
ELECTRONIQUE ET TÉLÉCOMMUNICATIONS

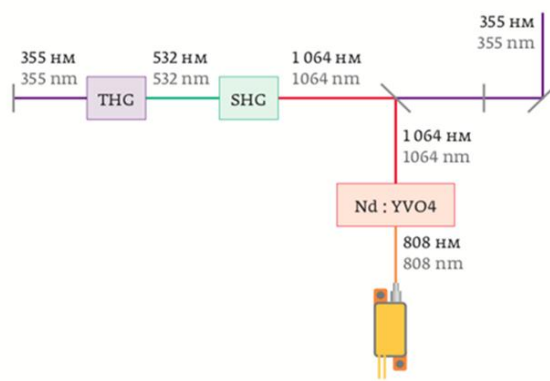

Fig. 2. **Third harmonic generation scheme**

Conclusions. The efficiency of heating metals is influenced by the wavelength of the laser, with shorter wavelengths proving more effective, as reflected in the decreased reflectivity of metals at shorter wavelengths. Additionally, the generation of the third harmonic in a solid-state laser involves leveraging nonlinear optical phenomena. By exciting the second harmonic and combining the main and second harmonics, the third harmonic with a shorter wavelength is emitted, enhancing the efficiency of metal processing.

REFERENCES:

- [1] V. V. Girzhon, O. V. Smolyakov, O. V. Ovchinnikov, O. V. Zavgorodny, *Metallofiz. Noveishie Tekhnol.* 44 No 3, 383 (2022).
- [2] D. Nolan, S. W. Huang, V. Leskovsek, S. Braun, *Surf.Coat. Technol.* 200, 5698 (2006).
- [3] O.S. Hnatenko, O.V. Afanasieva, N.O. Lalazarova, Yu.S. Kurskoy, E.N. Odarenko, Y.V. Sashkova, O.V. Ivanchenko, *J. Nano- Electron. Phys.* 15 No 1, 01007 (2023).
- [4] M. Kukliński, M. Szymański, D. Przystacki, *Archives of Mechanical Technology and Materials* 39, 46 (2019).