

I. NEVLIUDOV, M. VZHESNIEVSKYI, Y. ROMASHOV, O. CHALA

## MATHEMATICAL MODELING OF MECHATRONIC SHUTTLES AS AUTOMATION OBJECTS FOR MULTILEVEL SYSTEMS OF INTRA-WAREHOUSE LOGISTICS

**The subject** of the study is the mathematical modeling of mechatronic shuttles of multilevel intra-warehouse logistics systems. **The purpose of the article** is to ensure energy efficiency and high productivity of multilevel warehouse logistics systems by developing mathematical models of mechatronic electromechanical drives as part of automated autonomous shuttle systems (*Pallet Shuttle*). To achieve this goal, it is necessary to solve the following tasks: to build a mathematical model of the processes occurring in the transportation shuttle as an electromechanical and mechatronic system; to build a mathematical model of the transportation shuttle as an automation object and to obtain a transfer function of the autonomous shuttle system for automatic control of its speed. **Conclusions.** The paper develops generalized approaches to the construction of mathematical models of electric drives as automation objects. The developed approach assumes that the linearized mathematical model of an electric drive as an automation object is represented as a linear differential equation with constant coefficients that relate the control and the controlled parameter. The construction of such a differential equation is proposed to be carried out by generalizing the properties inherent in electromechanical systems, and it is assumed that these properties are represented by Lagrange equations of the 2nd kind using electromechanical analogies. As a result of the research, it was shown that the use of this approach leads to a definite equation of the mathematical model of the mechatronic shuttle as an automation object. It is shown that the linearized mathematical model of the shuttle as an automation object should be determined by a differential equation of at least the second order. The research results prove the possibility of improving automation systems in design by taking into account the properties inherent in shuttles as electromechanical and mechatronic systems in more detail. It is shown that the use of this approach leads to a definite equation of the mathematical model of the mechatronic shuttle as an automation object, but it is generally almost impossible to obtain such an equation explicitly. To illustrate the proposed approach, we consider the modeling of a typical mechatronic electric drive of machines used in automated storages and present the results of modeling processes in the electric drive. It is shown that the linearized mathematical model of a mechatronic shuttle as an automation object should be determined by a differential equation of at least the second order. The research results show the possibility of improving automation systems during design due to a more detailed consideration of the properties inherent in shuttles as mechatronic electromechanical systems.

**Keywords:** automation; transfer function; cyber-physical systems; Industry 4.0; mechatronic electric drive; Pallet Shuttle; mathematical modeling.

### Introduction

One of the key conditions for high labor productivity growth in the industry is the continuous improvement of the technological equipment fleet. This is achieved primarily by replacing outdated equipment with new, modern ones.

Logistical problems are relevant for every company that deals with inventory.

A modern trend in warehouse automation is the use of shuttle systems for warehouse maintenance and warehouse preparation areas. Traditionally, shuttles are usually realized with pulling cables. In terms of flexibility and the ability to move around the warehouse and production, this causes certain problems that can be solved by using autonomous shuttles.

The family of shuttles includes cable cars and automatic distribution vehicles. Cable cars and automatic

distribution vehicles are powered by electricity and run on horizontal rails. They are placed on the rails by a vehicle, the so-called carrier, and can only travel in a straight line. Changes of course are made by means of turnouts and shifting to parallel tracks using mobile bogies. Height differences are covered by lifts.

Electrically driven shuttles are usually connected to the carrier by means of a drag cable. Only in the latest developments are autonomous shuttles being designed, providing for new, expanded applications.

Thus, the task of modernizing mechatronic electric drives as part of multi-level intra-warehouse logistics systems with minimal financial and time costs is becoming urgent. A possible solution is to modernize equipment by synthesizing IIoT technologies and modern sensors.

The ability to significantly improve the efficiency of the existing equipment fleet, with low costs and quick payback, through modernization is the reason why such

work is paid to production in solving a number of intra-warehouse logistics issues.

Thus, by modernizing outdated equipment to perform specific functions of shuttle systems, replacing individual systems and equipment units, it is possible to bring production to modern Industry 4.0 standards, including elements of cyber-physical approaches, without huge capital expenditures [1]. Modernization works include structural modifications of equipment [2], which are aimed at expanding technological capabilities or changing the technological purpose of equipment [3–4]. These design changes also allow to extend the effective life of the equipment, and in some cases, even significantly increase its productivity and reduce energy consumption.

### **Analysis of recent research and publications**

---

The concept of logistics automation, using Industry 4.0 cyber-physical approaches, is an important tool for increasing the productivity of logistics operators through the use of computer software, robotics, or robotics technologies. There are many different technologies related to automation in logistics. New hardware and software are constantly being developed. The main trends such as automation and digitalization of logistics processes, in particular, automation of warehouse complexes or their components using Industry 4.0 cyber-physical approaches, have been studied [5].

The main potential of logistics lies in the optimization of material flow management. According to research by UK scientists, approximately 70% of the final cost of goods that reach the consumer is the cost of logistics operations (transportation, warehousing, storage, packaging, etc.) associated with the movement of material flow [6].

Thus, the main object of logistics is material flows and ways to realize their movement [7].

The use of multi-level shuttle systems partially solves the problem of transportation and storage of large volumes of products in warehouses [8–9]. However, a significant drawback is the high cost of shuttle structures and their installation, maintenance, and low energy efficiency [10].

Automation and improvement of tent systems in logistics, through the use of cyber-physical approaches, is one of the shortest ways to increase the parameters of reducing the time of transportation, sorting, storage and increasing energy efficiency and flexibility of intra-warehouse logistics processes [11].

Despite the availability of publications on the modeling of mechatronic systems in logistics, they are either purely general materials or relate only to mechanical and system engineers [12]. At present, automation researchers lack objective recommendations on theoretical and practical ways to build mathematical models of mechatronic shuttles for multilevel systems, so their development is an urgent task. The paper proposes ways to improve automation systems in design by taking into account in more detail the properties inherent in shuttles as electromechanical and mechatronic systems based on mathematical modeling.

The aim of the work is to ensure energy efficiency and high performance of multilevel warehouse logistics systems by developing mathematical models of mechatronic electromechanical drives as part of automated autonomous shuttle systems (Pallet Shuttle).

### **Theoretical foundations of mathematical modeling of the mechatronic shuttle as an automation object**

---

Mechatronic systems, as one of the types of dynamic systems [10], are designed to realize a given movement and are based on some kind of actuator and drive – electromechanical, hydraulic, or some other. Examples of modern mechatronic devices are machine tool modules and industrial robots, household appliances, shuttles in logistics warehouse systems, etc. Typically, mechatronic systems are modeled at the highest level of abstraction (macro level), where a distinction is made between structural (block) and physical multidomain approaches, each of which has its advantages and disadvantages [11]. At the same time, each of the two methods may have certain features of the mathematical core. The accuracy of modeling depends on the number of system properties taken into account, while the accuracy of simulation depends on the tools selected by the user and the consideration of the features of the developed model. Any mechatronic system requires control, and must be identified to build its model in order to create the necessary control device that provides a complex coordinated movement of the mechanical part [10]. The modeling of mechatronic systems includes the following stages of studying the characteristics of the system as a whole, the automatic control system and the automation object, and the construction and study of models of the mechanical part.

An automation object differs from any other object of mathematical modeling by the presence of a defined

controlled parameter  $x$  and the presence of a defined parameter  $u$ , which affects the value of the controlled parameter. The specificity of the mechatronic shuttle is the presence of an electric motor as a source of torque, which is formed by the applied electric supply voltage [13]. Therefore, taking into account these circumstances and the purpose of the mechatronic shuttle, the angular velocity of the rotor of the drive electric motor can be considered as a generalized controlled parameter  $x$  of the mechatronic shuttle, and the supply voltage of the drive electric motor can be taken as a generalized parameter  $u$  characterizing the control, which generally depends on the time  $t$ :

$$x = x(t), u = u(t). \quad (1)$$

Generalization is understood here in the sense that the controlled parameter and the control parameter (1) can be used regardless of the design, purpose, and operating modes of the mechatronic electric drive.

The mathematical model of the mechatronic shuttle as an automation object should generally determine the dependence of the controlled parameter  $x$  on the control parameter  $u$  and should be presented in a convenient form for further use in the design of the automatic control system of the electric drive. It is clear that, given the variety of designs and characteristics of mechatronic shuttles, it is quite difficult to propose a generalized form of the mathematical model of a mechatronic shuttle as an automation object, but from the point of view of convenient further use in the design of a mechatronic shuttle automatic control system, the most convenient form of such a model should correspond to a linear ordinary differential equation with constant coefficients and the required number of initial conditions [14]:

$$a_n \frac{d^n x}{dt^n} + a_{n-1} \frac{d^{n-1} x}{dt^{n-1}} + \dots + a_1 \frac{dx}{dt} + a_0 x = b_0 u, \quad (2)$$

$$x(t_0) = x_0^{(0)}, \frac{dx}{dt}(t_0) = x_0^{(1)}, \dots, \frac{d^{n-1} x}{dt^{n-1}}(t_0) = x_0^{(n-1)}, \quad (3)$$

where  $n$  and  $m$  – order of the differential equation and the control derivative;

$a_n, a_{n-1}, \dots, a_0, b_0$  – parameters of the mathematical model;

$$L \approx \frac{1}{2} \sum_{i=1}^N \sum_{j=1}^N m_{ij} \dot{q}_i \dot{q}_j - \frac{1}{2} \sum_{i=1}^N \sum_{j=1}^N c_{ij} q_i q_j, R \approx \frac{1}{2} \sum_{i=1}^N \sum_{j=1}^N b_{ij} \dot{q}_i \dot{q}_j, Q_k \approx \sum_{j=1}^N p_{kj} \dot{q}_j + p_k u, \quad (5)$$

where  $m_{ij}$ ,  $c_{ij}$  and  $b_{ij}$  – generalized characteristics of inertia, stiffness and viscosity;

$t_0$  – given moment in time;

$x_0^{(0)}, x_0^{(1)}, \dots, x_0^{(n-1)}$  – set values of the controlled

parameter and its derivatives at the initial time  $t = t_0$ .

The form (2), (3) is indeed the most convenient for formulating a mathematical model of a mechatronic shuttle as an automation object, since it allows solving all engineering issues related to the design of automated control systems, including the design of automatic controllers. At the same time, there is no general approach to constructing the differential equation (2) for modeling shuttles as automation objects, which in some way complicates the solution of engineering problems in the design of automated control systems.

To build the mathematical model (2), (3) of mechatronic shuttles as automation objects, it is proposed to consider the differential equation (2) as a form for generalizing the properties of processes inherent in shuttles as electromechanical systems. Taking into account the known electromechanical analogies, we have the most general form of a mathematical model of processes for a fairly wide class of mechatronic shuttles of various designs and purposes in the form of Lagrange equations of the 2nd kind:

$$\frac{d}{dt} \frac{\partial L}{\partial \dot{q}_k} - \frac{\partial L}{\partial q_k} = - \frac{\partial R}{\partial \dot{q}_k} + Q_k, k = 1, 2, \dots, N, \quad (4)$$

where  $N$  – number of freedom degrees of the shuttle as an electromechanical system;

$q_1, q_2, \dots, q_N$  and  $\dot{q}_1, \dot{q}_2, \dots, \dot{q}_N$  – generalized coordinates and velocities of the shuttle as an electromechanical system;

$L$  – Lagrange function (kinetic potential);

$R$  – Rayleigh dissipative function;

$Q_k$  – is a generalized driving force, which, of course, is neither potential nor dissipative.

It is clear that the peculiarities of the designs and schematic solutions of the mechanical and electrical parts of the shuttle are taken into account in equations (4) due to the appropriate proper form of generalized coordinates, Lagrange function, dissipative Rayleigh function, and generalized forces, which can be appropriately linearized and represented as:

$p_{kj}$  and  $p_k$  ( $k = 1, 2, \dots, N$ ) – generalized characteristics of the driving forces of the electric drive as an electromechanical system.

Taking into account the linearized expressions (5), the differential equations (4) will take the following form:

$$\sum_{j=1}^N m_{kj} \ddot{q}_j + \sum_{j=1}^N b_{kj} \dot{q}_j + \sum_{j=1}^N c_{kj} q_j = \sum_{j=1}^N p_{kj} \dot{q}_j + p_k u, \quad (6)$$

$$k = 1, 2, \dots, N.$$

Equation (6), of course, should be considered with initial conditions:

$$q_k(t_0) = q_k^{(0)}, \quad \dot{q}_k(t_0) = \dot{q}_k^{(0)}, \quad k = 1, 2, \dots, N, \quad (7)$$

where  $q_k^{(0)}$  and  $\dot{q}_k^{(0)}$  specified values of the generalized coordinate and velocity at the initial moment of time  $t = t_0$ .

In the form of (6), (7), we have a generalized linearized mathematical model of electric drive processes as in an electromechanical system, and such a model

$$\frac{dx}{dt} = \sum_{j=1}^N \frac{\partial \omega}{\partial q_j} \dot{q}_j + \sum_{j=1}^N \frac{\partial \omega}{\partial \dot{q}_j} \ddot{q}_j, \quad x(t_0) = \omega(q_1^{(0)}, \dots, q_N^{(0)}, \dot{q}_1^{(0)}, \dots, \dot{q}_N^{(0)}). \quad (9)$$

Thus, in the form of (6), (7), (9), we have an identical form of representation of the mathematical model (2), (3) of the mechatronic shuttle as an automation object. It is clear that by identical transformations of the differential equations (6), (9), we will have a differential equation of the form (2). It is also clear that the identical transformations of equations (6), (9) to the form (2) in the general case can be quite complicated, so that it will be practically impossible to perform them, although for some cases of equations (6), (9) such transformations are quite possible. Since in the form of (6), (9) we have a system  $N$  of differential equations of the second order and one differential equation of the first order, in general, we can state that the order of the differential equation (2) is as follows:

$$n = 2N + 1. \quad (10)$$

It should be noted that in some cases, the order of the differential equation (2) may be less than the value of (10) due to the form of differential equations (6) and relation (8). In general, relation (10) clearly shows that a more detailed modeling of processes in the shuttle as an electromechanical system by increasing the number of degrees of freedom and generalized coordinates [15] will lead to a complication of the mathematical model of the mechatronic shuttle as an automation object. Thus, we have opportunities to improve automation systems in design by taking into account in more detail the properties inherent in mechatronic shuttles as electromechanical systems [16].

is generalized in the sense that it covers a fairly wide class of mechatronic shuttles for various purposes. It is quite clear that the controlled parameter of the shuttle, introduced in relations (1), is determined by the current state of the shuttle, which can be mathematically written as follows:

$$x(t) = \omega(q_1(t), \dots, q_N(t), \dot{q}_1(t), \dots, \dot{q}_N(t)), \quad (8)$$

where  $\omega(\dots)$  – some given function that determines the controlled parameter, which is generally the angular velocity of the rotor of an electric motor, through the generalized coordinates and speeds of the mechatronic shuttle as an electromechanical system. mechatronic shuttle as an automation object, we determine the derivative and the value at the initial time of the controlled parameter (8):

#### **An example of mathematical modeling of the mechatronic shuttle of the electric drive of automated storage machines as an automation object**

To further extend electromechanization and automation to a wider class of operations, various means are proposed [17], including automatic shuttles (Fig. 1, a) to ensure intra-warehouse transportation of goods in the spaces between rows of racks. It is clear that the automation of such transportation shuttles is fundamental in contrast to other warehouse equipment, since, in addition to various advantages, it also provides smaller dimensions due to the absence of a workplace for a human operator, which will reduce the space between rows of racks and, as a result, reduce the length of transportation routes. In such shuttles (Fig. 1, a), it is most convenient to use electric drives to provide traction, since they can be quite small in size and do not generate emissions into the environment, such as drives with internal combustion engines, which is actually quite important for closed warehouses. Thus, we have a transportation shuttle (Fig. 1, a) as an automation object in the form of a complex mechatronic electromechanical system, which can be considered as a special case of an industrial electric drive. It is clear that to ensure the automation of the shuttle, it is necessary to have its mathematical model as an automation object. Therefore, to illustrate the capabilities and techniques of using the proposed generalized approaches, we will further consider a simplified schematic diagram of the mechanical part (Fig. 1, c) and DC traction motors (Fig. 1, c) of the

mechatronic shuttle (Fig. 1, a) to simplify the identical mathematical transformations that are not fundamental to this study to obtain the differential equation (2) of the mathematical model of the mechatronic shuttle as an automation object.

It should be noted that the transportation shuttle (Fig. 1, a) is a rather complex automation object, since it should provide automation of both steady-state and transient modes in the presence of special requirements for positioning accuracy [18] and, possibly, smooth movements with the desired minimization of energy consumption. It is clear that solving each of these and other special automation tasks will require appropriate mathematical models of the shuttle as an automation

object, but here we will limit ourselves to considering the automation task of ensuring steady-state transportation of cargo by the shuttle at a given speed. In such a problem, the following should be chosen as parameters (1):

$$x(t) = \dot{s} - v, \quad u(t) = \tilde{U}_e, \quad (11)$$

where  $s = s(t)$  – a rectilinear coordinate that determines the current position of the shuttle on the guides (Fig. 1, a and Fig. 1, b);

$v > 0$  – the desired speed of the shuttle during the transportation of goods;

$\tilde{U}_e = \tilde{U}_e(t)$  – supply voltage of traction electric motors (Fig. 1, c).

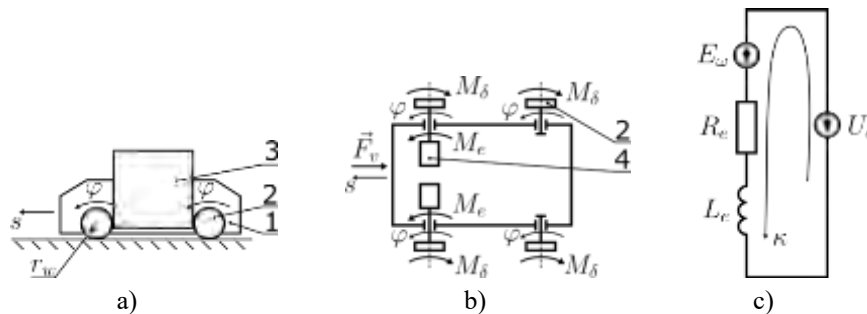

**Fig. 1.** General (a), kinematic (b) schemes and equivalent electrical circuit of electric motors (c) of the shuttle for intra-warehouse transportation (1 – shuttle; 2 – wheel; 3 – cargo; 4 – electric motor)

The mathematical model of the mechatronic shuttle as an automation object should make it possible to establish a connection between the parameters (11), and the most convenient form of such a model should correspond to (2), (3). Therefore, to obtain the mathematical model (2), (3) of the shuttle (Fig. 1) as an automation object with parameters (11), we consider the following processes inherent in the shuttle as an electromechanical system.

First, let's consider the mechanical part of the shuttle, which represents the automation object under study. So, we have a shuttle 1 that carries a load 3 on wheels 2 in such a way that the position of the shuttle on the guides is determined by the coordinate  $s$ , and the rotation of the wheels is determined by the angle of rotation  $\varphi$ , as shown in Fig. 1, a. We further assume that the movement of the shuttle is provided by two electric motors 4 of direct current, each of which is directly connected to the corresponding wheel, and the other two wheels of the shuttle are exclusively supporting, as shown in Fig. 1, б. We further assume that the coordinate and the angle of rotation are related by the following relation:

$$\dot{s} = r_w \dot{\varphi}, \quad (12)$$

where  $r_w$  – radius of the shuttle wheels (Fig. 1, a).

We take into account rolling friction and viscous resistance to shuttle movement:

$$|M_\delta| \approx \frac{1}{4} mg \delta, \quad |\vec{F}_v| = b |\dot{s}|, \quad (13)$$

where  $M_\delta$  and  $\vec{F}_v$  – wheel rolling friction moment and total viscous drag force of the shuttle;

$m$  – gross weight of the shuttle and  $g = 9,81 \text{ m/c}^2$ ;

$\delta$  and  $b$  – the rolling friction coefficient of the wheels and the integral coefficient of the shuttle's viscous pore.

We further assume that the movement is provided by electromagnetic torques  $M_e$  (Fig. 1, b), which are formed as a result of supplying DC supply voltage to traction electric motors  $U_e$  and [20, 21] is determined by the electric charge of the rotor of an electric motor:

$$M_e = B_e \dot{\kappa}, \quad (14)$$

where  $M_e$  – electromagnetic torque generated by an electric motor;

$B_e$  and  $\kappa = \kappa(t)$  – electromechanical characteristic and electric charge in the rotor circuit of a DC traction electric motor.

It is clear that to determine the electromagnetic torque (14), we should consider the electrical part of the shuttle, which will be represented as an equivalent electrical circuit consisting of series-connected active resistances  $R_e$ , индуктивного опоры  $L_e$ , as well as sources  $E_\omega$  and  $U_e$  electromotive force (Fig. 1, c). Source of electromotive force  $U_e$  is actually a source of energy that powers the shuttle, a source  $E_\omega$  electromotive force is an electromotive force arising from the rotation of the rotor winding conductors with electric current in the magnetic field of an electric motor and is defined as follows:

$$E_\omega = B_e \dot{\varphi}. \quad (15)$$

It should be noted that the electromotive force  $E_\omega$  counteracts the electromotive force  $U_e$ , which leads to the rotation of the rotor of the electric motor (Fig. 1, c).

Within the framework of the accepted schematization of the mechatronic shuttle as an electromechanical system (Fig. 1), taking into account relations (12)–(15), we can assume that the processes in such a system are determined by two generalized coordinates:

$$q_1 = \varphi, \quad q_2 = \kappa. \quad (16)$$

Thus, taking into account the adopted generalized coordinates (16), we have the following Lagrange function, Rayleigh function, and generalized forces:

$$L = \frac{1}{2} J \dot{q}_1^2 + 2 \frac{1}{2} L_e \dot{q}_2^2, \quad R = \frac{1}{2} B \dot{q}_1^2 + 2 \frac{1}{2} R_e \dot{q}_2^2, \quad (17)$$

$$Q_1 = -mg\delta + 2B_e \dot{q}_2, \quad Q_2 = -2B_e \dot{q}_1 + 2U_e, \quad (18)$$

where  $J$  and  $B$  – are the generalized moment of inertia and viscous drag coefficient reduced to the axis of rotation of the rotor of a traction electric motor.

Expressions (17), (18) and the values  $J$  and  $B$  contained in expression (17) can be obtained accordingly, which is not the main purpose of this study, so we present the final results here:

$$J = mr_w^2 + 2J_e + 4J_w, \quad B = br_w^2, \quad (19)$$

where  $J_e$  and  $J_w$  – moments of inertia of the rotor of the traction electric motor and the shuttle wheel relative to their axes of rotation.

It should be noted that the choice of the first generalized coordinate (16) corresponds to the generally accepted approaches of machine dynamics [19].

$$\frac{L_e J}{2B_e} \ddot{q}_1 + \frac{L_e B + R_e J}{2B_e r_w} \ddot{q}_1 + \left( B_e + \frac{R_e B}{2B_e} \right) \dot{q}_1 = -\frac{R_e mg \delta}{2B_e} + U_e(t). \quad (25)$$

Thus, taking into account expressions (17), (18), the Lagrange equations of the 2nd kind (4) will lead to a system of two second-order differential equations:

$$\begin{aligned} J \ddot{q}_1 &= -mg\delta - B \dot{q}_1 + 2B_e \dot{q}_2, \\ L_e \ddot{q}_2 &= -B_e \dot{q}_1 - R_e \dot{q}_2 + U_e(t). \end{aligned} \quad (20)$$

It is clear that equation (20) should be considered with the following initial conditions:

$$q_1(t_0) = q_1^{(0)}, \quad \dot{q}_1(t_0) = \dot{q}_1^{(0)}, \quad q_2(t_0) = q_2^{(0)}, \quad \dot{q}_2(t_0) = \dot{q}_2^{(0)}, \quad (21)$$

where  $q_1^{(0)}$  and  $\dot{q}_1^{(0)}$  set values of the angle of rotation and angular velocity of the shuttle wheels at the initial moment of time  $t = t_0$ ;

$q_2^{(0)}$  and  $\dot{q}_2^{(0)}$  set values of the electric charge and current strength of the rotor winding of the shuttle traction electric motors at the initial moment of time  $t = t_0$ .

Thus, the mathematical model of processes in a mechatronic shuttle as an electromechanical system, in this case, a transportation shuttle (Fig. 1), summarized in the form of (6), (7), has acquired a partial form [20, 21]. Generalized in the form of (8), the controlled parameter of the electric drive [20], in this case of the transportation shuttle (Fig. 1), taking into account relations (11), (12), (15), will take the form

$$x = r_w \dot{q}_1 - v. \quad (22)$$

Due to the relation (22), we have an additional differential equation for determining the controlled parameter, generally represented in the form of (9), as follows:

$$\dot{x} = -\frac{r_w mg}{J} \delta - \frac{r_w B}{J} \dot{q}_1 + \frac{r_w 2B_e}{J} \dot{q}_2, \quad x(t_0) = r_w \dot{q}_1^{(0)} - v. \quad (23)$$

Thus, the mathematical model of the transporting mechatronic shuttle (Fig. 1) as an automation object is indirectly represented in the form of (20), (21), (23), and this form of writing the mathematical model is consistent with the above generalized result (6), (7), (9). In this case, it is possible to obtain the equations of the mathematical model of the mechatronic shuttle as an automation object in an analytical form. To do this, first, using the first differential equation (20), we need to determine the rotor winding current of the electric motor:

$$\dot{q}_2 = \frac{mg\delta}{2B_e} + \frac{J}{2B_e} \ddot{q}_1 + \frac{B}{2B_e} \dot{q}_1. \quad (24)$$

Next, we take into account the relation (24) in the second differential equation (20) and obtain:

To reformulate the differential equation (25) with respect to the controlled parameter, we use the following relations (22):

$$\dot{q}_1 = (x + v)/r_w. \quad (26)$$

$$\frac{L_e J}{2B_e r_w} \ddot{x} + \frac{L_e B + R_e J}{2B_e r_w} \dot{x} + \frac{1}{r_w} \left( B_e + \frac{R_e B}{2B_e} \right) (x + v) = -\frac{R_e mg \delta}{2B_e} + U_e(t). \quad (27)$$

Consider further that the supply voltage of the electric motors to ensure a constant speed of the mechatronic shuttle is as follows:

$$U_e(t) = \bar{U}_e(v) + \tilde{U}_e(t), \quad (28)$$

where  $\bar{U}_e(v)$  – Steady-state stress required to maintain a given desired speed  $v$  of cargo transportation;

$\tilde{U}_e(t)$  – is the alternating stress required to compensate for naturally occurring uncontrolled motion

$$x(t_0) = r_w \dot{q}_1^{(0)} - v, \quad \dot{x}(t_0) = -\frac{r_w mg}{J} \delta - \frac{r_w B}{J} \dot{q}_1^{(0)} + \frac{r_w 2B_e}{J} \dot{q}_2^{(0)}. \quad (31)$$

Thus, in the direct form of (30), (31), a mathematical model of the transporting mechatronic shuttle as an automation object was obtained, and this

$$n = 2, \quad a_2 = \frac{L_e J}{2B_e r_w}, \quad a_1 = \frac{L_e B + R_e J}{2B_e r_w}, \quad a_0 = \frac{1}{r_w} \left( B_e + \frac{R_e B}{2B_e} \right), \quad b_0 = 1, \quad (32)$$

$$x_0^{(0)} = r_w \dot{q}_1^{(0)} - v, \quad x_0^{(1)} = -\frac{r_w mg}{J} \delta - \frac{r_w B}{J} \dot{q}_1^{(0)} + \frac{r_w 2B_e}{J} \dot{q}_2^{(0)}. \quad (33)$$

It is noteworthy that the properties of the transport shuttle (29)-(31) as an automation object can be represented by a transfer function of the following form, taking into account the notation (32)

$$W(s) = \frac{1}{a_2 s^2 + a_1 s + a_0}, \quad (34)$$

where  $W(s)$  – transfer function that defines the transporting mechatronic shuttle as an automation object;

$s$  – is a complex variable generated by the integral Laplace transform.

It should be emphasized that the mathematical model (30), (31) of the transport shuttle as an automation object is obtained in the direct form (2), (3), (32), (33) only due to the form (20), (21) of the mathematical model of processes in the mechatronic shuttle as an electromechanical system. In the general case, it is impossible to obtain a mathematical model of the automation object in the direct form of (2), (3), and it will be necessary to use a mathematical model in an indirect

Taking into account expressions (23), (26), the differential equation (25) will take the following form:

disturbances to ensure a given desired speed of the transportation shuttle.

Relations (27)–(29), taking into account the control parameter adopted in the form of (11) and expressions (23), will lead us to the following final result:

$$\bar{U}_e(v) = \frac{v}{r_w} \left( B_e + \frac{R_e B}{2B_e} \right) + \frac{R_e}{2B_e} mg \delta, \quad (29)$$

$$\frac{L_e J}{2B_e r_w} \ddot{x} + \frac{L_e B + R_e J}{2B_e r_w} \dot{x} + \frac{1}{r_w} \left( B_e + \frac{R_e B}{2B_e} \right) x = u(t), \quad (30)$$

model is a special case of the model (2), (3) of the general form, in which

form, which contains a mathematical model of processes and the definition of the controlled parameter. It is clear that the mathematical model of the automation object in such an indirect form is more informative, but for the design of automation systems, a mathematical model that links the controlled parameter and control is more convenient.

Further research is planned to continue in the direction of modeling processes in the transportation shuttle. Such a study necessarily requires substantiation of the results obtained in the future to confirm the absence of errors in the software used and in the computer models developed, as well as the correct use of the software. It is clear that such substantiation involves both testing of individual software components and testing of the software as a whole. At the first stage, it is planned to develop and test a computer model based on the justification of the parameters of the processes that will occur in the mechatronic transportation shuttle during its acceleration from a stationary state by

a constant electric voltage instantly applied to the driving electric motors. This will make it possible to ensure energy efficiency and high productivity of multi-level warehouse logistics systems.

The team of authors would like to express their gratitude to Kapelou LLC for supporting the research of the Department of Computer-Integrated Technologies, Automation and Robotics of the Kharkiv National University of Radio Electronics (Kharkiv, Ukraine) in the field of automation, logistics of intra-warehouse systems and mechatronics and robotics.

### Conclusions

The paper develops approaches to constructing mathematical models of mechatronic shuttles as automation objects. The developed approach assumes that a linearized mathematical model of a mechatronic shuttle as an automation object is presented in the form of a linear differential equation with constant coefficients that connects the control and the controlled parameter. The construction of such a differential equation is proposed to be carried out by generalizing the properties inherent in mechatronic electric drives as

electromechanical systems, and it is assumed that these properties are represented by Lagrange equations of the 2nd kind using electromechanical analogies. It is shown that the use of this approach leads to a definite equation of the mathematical model of the mechatronic shuttle as an automation object, but it is practically impossible to obtain such an equation explicitly in the general case. To illustrate the proposed approach, we consider the modeling of a typical mechatronic electric drive of machines used in automated storages and present the results of modeling processes in the electric drive. It is shown that a linearized mathematical model of a mechatronic shuttle as an automation object should be determined by a differential equation of at least second order. The results of the study show the possibility of improving automation systems in the design due to a more detailed consideration of the properties inherent in mechatronic shuttles as mechatronic electromechanical systems. Further research will be aimed at conducting computer modeling taking into account the specific parameters of the mechatronic shuttle, which in the future will make it possible to ensure energy efficiency and high productivity of multilevel warehouse logistics systems in general.

### References

1. Liashuk, O. L., Hevko, R. B., Dziura, V. O. (2019), "The development and modernization of transport and technological mechanisms of machines and possession" ["Stvorennia ta modernizatsiia transportno-tehnolohichnykh mekhanizmiv mashyn i obladannia"] [Electronic resource]: monograph. NTU. 167 p. available at: <https://elartu.tntu.edu.ua/handle/lib/29468>
2. Nevliudov, I., Yevsieiev, V., Maksymova, S., Filippenko, I. (2020), "Development of an Architectural-Logical Model to Automate the Management of the Process of Creating Complex Cyber-Physical Industrial Systems". *Eastern-European Journal of Enterprise Technologies*, 4(3(106)), P. 44–52. DOI: 10.15587/1729-4061.2020.210761
3. Frolov, A.V. (2021), "The Experience of the Portal Machine Control System Modernizing for Automatic Arc Welding and Surfacing in a Shielded Gas". *Current Problems and Ways of Industry Development: Equipment and Technologies*, No. 7, P. 622–631. DOI: [https://doi.org/10.1007/978-3-030-69421-0\\_66](https://doi.org/10.1007/978-3-030-69421-0_66)
4. Wąsik, M., Lis, K., Lech, K. and Mucha, Ł. (2018), "Model-Based Dynamic Structural Modification of Machine Tools". *Shock and Vibration*, Volume 2018. P.1-9. DOI: <https://doi.org/10.1155/2018/3469171>
5. Hryhorov, O. V. ta in. "Tekhnika materialnykh potokiv lohistychnykh system: navch. posib. "Kharkiv: NTU «KhPI», 2018. 496 p. available at: <https://repository.kpi.kharkov.ua/handle/KhPI-Press/39521>
6. Sanchez, Londono, D., Barbieri, G., Fumagalli, L. (2023), "Smart retrofitting in maintenance: a systematic literature review". *Journal of Intelligent Manufacturing*. Vol. 34(1). P. 1–9. DOI: 10.1007/s10845-022-02002-2
7. Alsudani, M.Q., et al. (2023), "Smart logistics with IoT-based enterprise management system using global manufacturing". *Journal of Combinatorial Optimization*. Vol. 45(2). 1179 p. DOI: 10.1007/s10878-022-00977-5
8. Akandere, G., Khajeh, E., Paksoy, T. (2023), "The internet of things and cyber physical systems". *Smart and Sustainable Operations and Supply Chain Management in Industry*. 4, P. 277–305. DOI:10.1201/9781003180302-14
9. Aleksiev, O., Aleksiev, V., Matsyi, O., & Matsyi, M. (2021), "End-to-end design of mechatronic industrial and automotive computer systems". *Bulletin of V.N. Karazin Kharkiv National University, Series «Mathematical Modeling. Information Technology. Automated Control Systems»*, 49, P. 6–15. DOI: <https://doi.org/10.26565/2304-6201-2021-49-01>

10. Nevliudov, I., Maksymova, S., Chala, O., Bronnikov, A., & Vzhesnievskyi, M. (2023), "Automated Logistics Processes Improvement in Logistics Facilities". *Multidisciplinary Journal of Science and Technology*, 3(3), P. 157–170. available at: <https://mjstjournal.com/index.php/mjst/article/view/202>

11. Yevsieiev, V. (2021), "Methods and models of cyber-physical process control in organizational and technical production facilities" ["Metody ta modeli kiber-fizychnoho keruvannya protsesamy v orhanizatsiino-tekhnichnykh vyrobnychkykh ob'ektakh"]: avtoref. dis. Kharkiv, NURE, 45 p. available at: <https://openarchive.nure.ua/handle/document/16097>

12. Mamalis, A.G., Nevliudov, I., Romashov, Yu. (2021), "An approach for numerical simulating and processing of measured electrical signals from board sensors installed on wheeled electro-mechanical platforms", *Journal of Instrumentation*. Vol. 16 (10). 10006 p. DOI: 10.1088/1748-0221/16/10/P10006

13. Alyokhina, S., Nevliudov, I., Romashov, Yu. (2021), "Safe Transportation of Nuclear Fuel Assemblies by Means of Wheeled Robotic Platforms", *Nuclear and Radiation Safety*, Vol. 3 (91), P. 43–50. DOI: [https://doi.org/10.32918/nrs.2021.3\(91\).05](https://doi.org/10.32918/nrs.2021.3(91).05)

14. Ge, Shuaishuai, Shuang, Hou, and Mingyao, Yao. (2023), "Electromechanical Coupling Dynamic Characteristics of the Dual-Motor Electric Drive System of Hybrid Electric Vehicles", *Energies* 16 (7), 3190 p. DOI: <https://doi.org/10.3390/en16073190>

15. Pletinckx, Cyril "Autonomous shuttles for a logistical warehouse : automatic design of the warehouse. Ecole polytechnique de Louvain, Université catholique de Louvain", 2021. Prom: Schaus, Pierre. available at: <http://hdl.handle.net/2078.1/thesis:30626>

16. Zhen, L., Wu, J., Li, H., Tan, Z., & Yuan, Y. (2023), "Scheduling multiple types of equipment in an automated warehouse". *Annals of Operations Research*, 322(2), P. 1119–1141. DOI: 10.1007/s10479-022-04935-6

17. Siciliano, G., Yu, Y., & Fottner, J. (2022), "Synergy between Shuttles and Stacker Cranes in Dynamic Hybrid Pallet Warehouses: Control Strategies and Performance Evaluation". *Anwendungen und Konzepte der Wirtschaftsinformatik*, Vol.15. P. 1–7. DOI: <https://doi.org/10.26034/lu.akwi.2022.3328>

18. Nevliudov, I., Romashov, Y. (2022), "Control of wheeled platforms straight motions taking into account jerk restrictions under speeding-up from the state of rest". *Visnyk of V. N. Karazin Kharkiv National University. Ser. Mathematics, Applied Mathematics and Mechanics*, Vol. 96, P. 4–22. <https://doi.org/10.26565/2221-5646-2022-96-01>

Received 30.11.2023

#### Відомості про авторів / About the Authors

**Невлюдов Ігор Шакирович** – доктор технічних наук, професор, Харківський національний університет радіоелектроніки, завідувач кафедри комп'ютерно-інтегрованих технологій, автоматизації та робототехніки, Харків, Україна; e-mail: [igor.nevliudov@nure.ua](mailto:igor.nevliudov@nure.ua); ORCID ID: <https://orcid.org/0000-0002-9837-2309>

**Вжеснівський Максим Олегович** – Харківський національний університет радіоелектроніки, аспірант кафедри комп'ютерно-інтегрованих технологій, автоматизації та робототехніки, Харків, Україна; e-mail: [maksym.vzhesnievskyi@nure.ua](mailto:maksym.vzhesnievskyi@nure.ua); ORCID ID: <https://orcid.org/0000-0002-7585-628X>

**Ромашов Юрій Володимирович** – доктор технічних наук, доцент, Харківський національний університет радіоелектроніки, професор кафедри комп'ютерно-інтегрованих технологій, автоматизації та робототехніки; Харківський національний університет імені В.Н. Каразіна, професор кафедри прикладної математики, Харків, Україна; e-mail: [yurii.romashov@nure.ua](mailto:yurii.romashov@nure.ua); ORCID ID: <https://orcid.org/0000-0001-8376-3510>

**Чала Олена Олександрівна** – кандидат технічних наук, доцент, Харківський національний університет радіоелектроніки, доцент кафедри комп'ютерно-інтегрованих технологій, автоматизації та робототехніки, Харків, Україна; e-mail: [olena.chala@nure.ua](mailto:olena.chala@nure.ua); ORCID ID: <https://orcid.org/0000-0003-2454-3774>

**Nevliudov Igor** – Doctor of Sciences (Engineering), Professor, Kharkiv National University of Radio Electronics, Head at the Department of Computer-Integrated Technologies, Automation and Robotics, Kharkiv, Ukraine.

**Vzhesnievskyi Maksym** – Kharkov National University of Radio Electronics, Post-Graduate Student at the Department of Computer-Integrated Technologies, Automation and Robotics, Kharkov, Ukraine.

**Romashov Yurii** – Doctor of Sciences (Engineering), Associate Professor, Kharkiv National University of Radio Electronics, Professor at the Department of Computer-Integrated Technologies, Automation and Robotics; V.N. Karazin Kharkiv National University, Professor at the Department of Applied Mathematics Department, Kharkiv, Ukraine.

**Chala Olena** – PhD (Engineering Sciences), Associate Professor, Kharkiv National University of Radio Electronics, Associate Professor at the Department of Computer-Integrated Technologies, Automation and Robotics, Kharkiv, Ukraine.

## МАТЕМАТИЧНЕ МОДЕЛЮВАННЯ МЕХАТРОННИХ ШАТЛІВ ЯК ОБ'ЄКТІВ АВТОМАТИЗАЦІЇ ДЛЯ БАГАТОРІВНЕВИХ СИСТЕМ ВНУТРІШНЬОСКЛАДСЬКОЇ ЛОГІСТИКИ

**Предметом** дослідження є математичне моделювання мехатронних шатлів багаторівневих систем внутрішньоскладської логістики. **Мета статті** – забезпечення енергоефективності та високої продуктивності багаторівневих систем складської логістики з допомогою розроблення математичних моделей мехатронних електромеханічних приводів у складі автоматизованих автономних шатлових систем (*Pallet Shuttle*). Для досягнення поставленої мети необхідно вирішити такі **завдання**: побудувати математичну модель процесів, що відбуваються в транспортувальному шатлі, як електромеханічної та мехатронної систем; розробити математичну модель транспортувального шатла як об'єкта автоматизації та отримання передатної функції автономної шатлової системи для автоматичного регулювання її швидкості. **Висновки.** У роботі розроблено узагальнені підходи щодо побудови математичних моделей електроприводів як об'єктів автоматизації. У запропонованому підході передбачено, що лінеаризована математична модель електроприводу як об'єкта автоматизації подана у вигляді лінійного диференційного рівняння зі сталими коефіцієнтами, що пов'язують керування та контрольований параметр. Побудову такого диференційного рівняння пропонується здійснювати способом узагальнення властивостей, притаманних електромеханічним системам, та передбачено, що ці властивості з використанням електромеханічних аналогій подані рівняннями Лагранжа 2-го роду. Унаслідок досліджень було показано, що використання такого підходу приводить до визначеного рівняння математичної моделі мехатронного шатла як об'єкта автоматизації. Показано, що лінеаризована математична модель шатла як об'єкта автоматизації має визначатися диференційним рівнянням не нижче другого порядку. За результатами досліджень доведено можливість удосконалення систем автоматизації в проєктуванні способом більш деталізованого врахування властивостей шатлів як електромеханічних і мехатронних системам. Доведено, що використання такого підходу приводить до визначеного рівняння математичної моделі мехатронного шатла як об'єкта автоматизації, але отримати таке рівняння в явному вигляді практично не можливо. Для ілюстрації запропонованого підходу розглянуто моделювання типового мехатронного електроприводу машин, що використовуються в автоматизованих сховищах, та наведені результати моделювання процесів у електроприводі. Показано, що лінеаризована математична модель мехатронного шатла як об'єкта автоматизації має визначатися диференційним рівнянням не нижче другого порядку. За результатами досліджень показано можливість удосконалення систем автоматизації під час проєктування завдяки більш деталізованому врахуванню властивостей шатлів як мехатронних електромеханічних систем.

**Ключові слова:** автоматизація; передатна функція; кіберфізичні ситеми; *Industry 4.0*; мехатронний електропривод; *Pallet Shuttle*; математичне моделювання.

### Бібліографічні описи / Bibliographic descriptions

Невлюдов І. Ш., Вжесневський М. О., Ромашов Ю. В., Чала О. О. Математичне моделювання мехатронних шатлів як об'єктів автоматизації для багаторівневих систем внутрішньоскладської логістики. *Сучасний стан наукових досліджень та технологій в промисловості*. 2023. № 4 (26). С. 135–144. DOI: <https://doi.org/10.30837/ITSSI.2023.26.135>

Nevliudov, I., Vzhesnievskiy, M., Romashov, Y., Chala, O. (2023), "Mathematical modeling of mechatronic shuttles as automation objects for multilevel systems of intra-warehouse logistics", *Innovative Technologies and Scientific Solutions for Industries*, No. 4 (26), P. 135–144. DOI: <https://doi.org/10.30837/ITSSI.2023.26.135>